

Notebook PC Service Manual

Model : 340S2

UNIWILL COMPUTER CORP.

No. 24 Pei Yuan Road
Chung Li Industrial Park, Chung Li City
Tao Yuan Hsien, Taiwan
R.O.C.
TEL: 886-3-461-6000
FAX: 886-3-461-6317
URL: [http:// www.uniwill.com.tw/](http://www.uniwill.com.tw/)

Notebook PC Service Manual

Model : 340S2

Chapter 1

General System Description

UNIWILL TECHNOLOGY CORP.

14F, 67 & 69, Section 1, Chung San RD.,
Hsin Chuang City, Taipei Hsien, Taiwan,
R.O.C.

TEL: 886-2-8991-6888

FAX: 886-2-8991-5666

URL: [http:// uniwill.com.tw/](http://uniwill.com.tw/)

1.1 System features

1.1.1 General features

- a. Support cost efficient CPU,
 - Celeron-128K 500~700 MHz in PPGA type
 - Pentium III 500~850 MHz in FC-PGA type
- b. Superior portability with all in one design
- c. Support high quality audio include 2 internal high power speaker
- d. Fully Support ACPI 1.0, meet PC98/PC99 requirement
- e. Built-in 56K modem for Data/Fax/Voice modem or Internet (optional)
- f. Support high performance hardware 2D/3D graphic engine
- g. Support high capacity memory up to 512 MB
- h. Support one most flexibility of 32-bit Cardbus slot and PCMCIA card

1.1.2 Hardware specification

A. CPU:

Celeron-128K 500MHz to 700MHz

- System bus frequency at 66 MHz
- Dynamic execution microarchitecture
- MMX technology capability
- Optimized for 32 bits AP and OS
- Power Management capability
- Integrated 32KB instruction and data L1 cache
- Integrated 128 KB instruction and data L2 cache

Pentium III 500MHz and 850MHz

- System bus frequency at 100MHz
- On-die 256KB L2 advanced transfer cache with ECC
- Dual independent bus architecture
- SIMD extensions for enhanced video, sound and 3D performance

- Dynamic execution micro architecture
- Power management capability
- Optimized for 32bits AP and OS
- Integrated 16KB instruction and 16KB data L1 cache
- 256bit cache data bus
- 8-way cache associatively
- ECC for system bus data

B. Core Logic

SIS 630

- Support 66/100 MHz FSB
- Power management capability
- Integrated AGP bus 2D/3D video processor
- Direct DVD MPEG-2 and AC-3 playback
- Accelerator for Direct 3D API
- Frame buffer share system memory up to 32MB
- Support PC100 VCM SDRAM
- Full support of ACPI and OS directed power management
- Integrated IDE controller support 2 channel ultra DMA transfers up to 66 MB/sec
- Integrated USB root hub
- Integrated audio controller with 64-voices Direct Sound channel support
- Integrated HSP modem
- Forwards PCI I/O and memory cycles into LPC bus

C. PCMCIA Controller

O2 Micro OZ6812

- ACPI-PCI bus power management interface specification Rev.1.0 compliant
- Compliant with PCI specification V2.1S, 1995 PC Card Standard and JEIDA 4.1
- Supports PCMCIA ATA specification
- Supports 5V/3.3V PC Cards and 3.3V Cardbus Cards
- Supports single PC card or Cardbus slot with hot insertion and removal
- Supports multiple FIFOs for PCI/CB data transfer
- Supports Direct memory access for PC/PCI and PC/Way on PC Card socket
- Win98IRQ and PC-97/98 compliant
- Integrated PC98 Subsystem Vendor ID support with auto lock bit

D. Embedded Controller / Keyboard Controller

NS PC87570

- Hot key for brightness, volume control
- ACPI controller
- SMB bus for smart battery
- Support Win-95 defined 3 new keys and down load-able key-matrix

E. Super I/O Controller

NS PC87393

- LPC System Interface with synchronous cycles, up to 33 MHz bus clock
- PC99 and ACPI Compliant

- Floppy Disk Controller (FDC)
- Support SPP, EPP and ECP Parallel port
- Software compatible with the 16550A and the 16450 serial port
- HP-IR, ASK-IR, Fast-IR support

F. Clock Generator

Realtek W83194R-630

- Multiple CPU clocks for SDRAM architecture
- Provide power down mode in slowing down CPU clock
- Spectrum modulation reduce EMI
- Provide programmable clocks

G. DSTN Encoder

NS CS9211

- Support 18 bits color digital pixel input
- Support SVGA DSTN and VESA FPMI SPEC.
- Programmable dither up to 64 levels
- Built in memory controller support both SDRAM and EDO RAM

1.2 System Specification

1.2.1 System Board

The major components of the computer include the system board, XGA color LCD display, FDD module, CD-ROM module (24X rotational speed max) / DVD module, keyboard, built-in glide pad with 2 click buttons, Lithium-ION battery pack, and AC adapter.

The system board incorporates CPU module, system memory, system and VGA BIOS, audio controller, CPU/ PCI bus controller, PCI / ISA bus controller. The **System Block Diagram** shows how these components are integrated as shown in the next page.

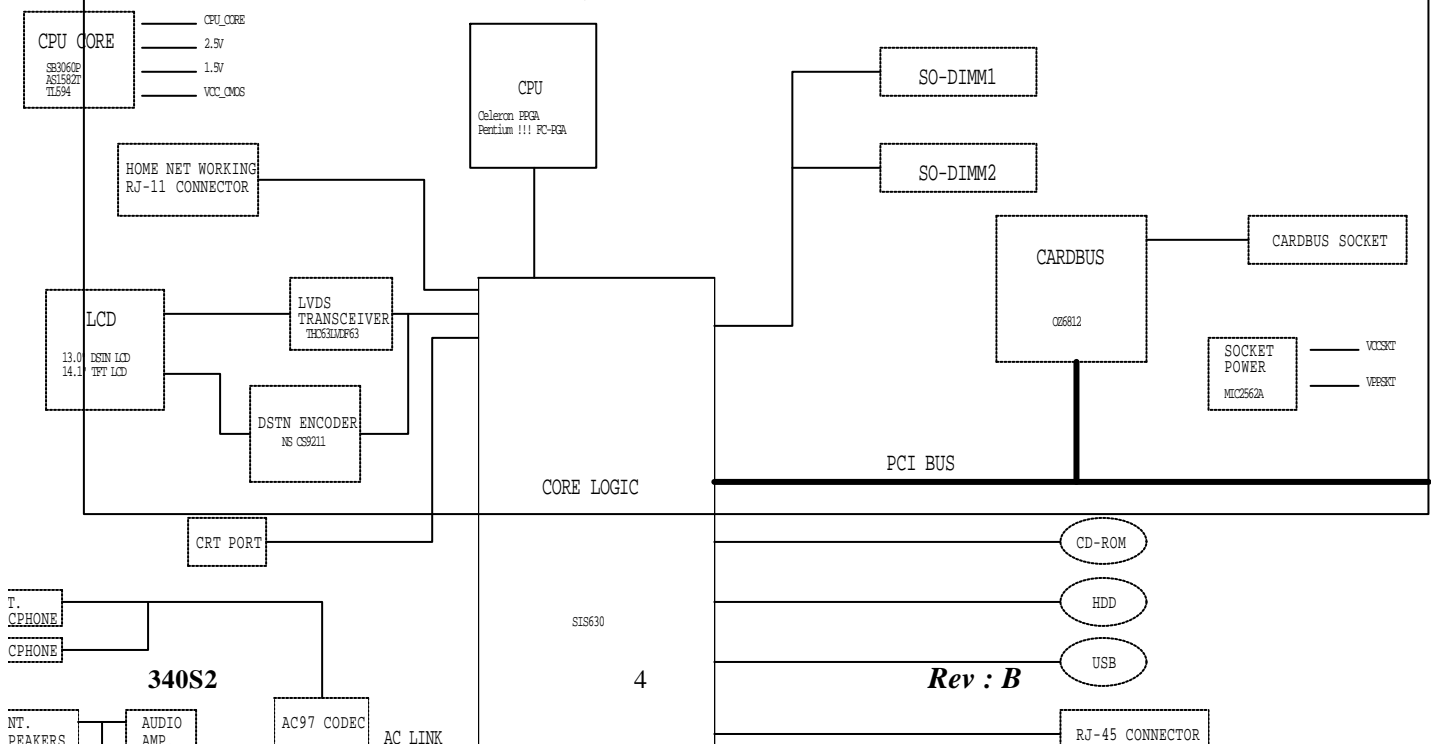

1.2.2 LCD Display

14.1" TFT
 13.3" TFT
 12.1" TFT
 13.0" HPA
 12.1" HPA

1.2.3 Power Plans

Power Source Descriptions

+5V : 5V power source
 +3V : 3.3V power source
 +12V : 12V power source
 CPU_Core : CPU Core power source.
 For Celeron, the voltage is 2.0V.
 For Pentium III, it is 1.8V.
 +1.5V : CPU AGTL+ termination power source
 VCC_CMOS : CPU CMOS pull up voltage.
 For Celeron, the voltage is 2.5V.
 For Pentium III, it is 1.5V.
 +2.5V : 2.5V power source
 +1.8V : 1.8V power source for SIS630
 KBVCC : KBC 3.3V power source
 KBVCCA : KBC AD/DA 3.3V reference voltage
 VCCRTC : Real time clock power source
 +5V_AUX : LAN 5V always power source
 +3V_AUX : LAN 3.3V always power source
 +3V_RX_TR : LAN 3.3V analog power source
 +3V_TX_TR : LAN 3.3V analog power source
 LCDVCC : LCD display 3.3V power source
 VIN : Inverter 12~20V power source
 ADAP+ : 20V Power supply from AC adapter
 AMPVDD : 5V analog power for audio

NMNC

1.2.4 Power Source Status

	5V	3.3V	12V	CPU _core	VCC_ CMOS	2.5V	1.5V	1.8V
FULL-ON	ON	ON	ON	ON	ON	ON	ON	ON
SLEEP	ON	ON	ON	ON	ON	ON	ON	ON
STD	OFF	OFF	OFF	OFF	OFF	OFF	OFF	OFF
SOFT-OFF	OFF	OFF	OFF	OFF	OFF	OFF	OFF	OFF

1.2.5 DC/DC Board

The DC/DC (system power) can support +3.3V, +5V, +12V for the main system.

The DC/DC (CPU power) can support +1.3V~2.05V, +1.8V, +2.5V for the CPU.

1.2.6 AC-DC Adapter

Input Voltage	: 100 ~ 240 ±10% AC
Input Frequency	: 50 ~ 60 Hz ±3Hz
Input AC current	: 1.5 @ 90 VAC
Efficiency	: Better than 80%
Inrush Current	: 50A @ 115VAC, 100A @ 230VAC
Holdup Time	: 5mS (minimum)
Output Voltage/Current	: 20V / 3.0A
Output Load Regulation	: ±5%

1.2.7 Inverter

Input Voltage	: 9-22 VDC
Output Voltage	: 620 Vrms @ 50-60KHz
Start Up Voltage	: 1400 Vrms (min.)
Brightness Adjust Range (tube current)	: 2.5mA rms – 5mA rms
Protection	: Open circuit protect, current limit protect

1.2.8 Battery Pack

A. Lithium – Ion Battery packs

- Battery type : Li-Ion
- Battery cells : 8 cells

- Battery Spec : 14.8V, 3200 mAH
- Battery power : 53 watts (total)
- Battery protection : over charge protect, over discharge protect, over temperature protect, short protect, over current protect

B. Ni-MH battery packs

- Battery type : Ni MH
- Battery cells : 10 cells
- Battery specs : 12V, 4500 mAh
- Battery power : 54 watts (total)
- Battery protection : over charge protect, over discharge protect, over temperature protect, short protect, over current protect

1.2.9 Memory Module

144 pins SO-DIMM, 3.3V, SDRAM

memory type = 1Mx16, 4Mx16, 16Mx16, 2Mx8, 8Mx8, 16Mx8

memory size = 16M, 32M, 64M, 128M,

memory clock = 66 MHz / 100MHz

Memory Configuration Table

DIMM 1	DIMM 2	Total
16M	0	16M
32M	0	32M
64M	0	64M
128M	0	128M
16M	16M	32M
16M	32M	48M
32M	32M	64M
16M	64M	80M
32M	64M	96M
64M	64M	128M
64M	128M	192M
128M	128M	256M

1.2.10 Interrupt Request Channel

Setting	Hardware using the setting
00	System timer
01	Standard 101/102-Key Microsoft Natural Keyboard
02	Programmable Interrupt Controller
03	IrDA V3.0 Fast Infrared Port
04	Communications Port (Com1)
06	Standard Floppy Disk Controller
07	ECP Printer Port (LPT1)
08	System CMOS/ Real Time Clock (RTC)
09	ACPI IRQ Holder for PCI IRQ Steering
09	SiS 900 PCI Fast Ethernet Adapter
10	ACPI IRQ Holder for PCI IRQ Steering
10	HAMR 5600 Voice Modem
10	O2Micro OZ6812 CardBus Controller
10	SIS 7018 Audio Driver
11	ACPI IRQ Holder for PCI IRQ Steering
11	SIS 7001 PCI to USB Open Host Controller
11	SIS 7001 PCI to USB Open Host Controller
11	SCI IRQ used by ACPI bus
12	Microsoft PS/2 Port Mouse
13	Numeric data processor
14	SIS 5513 Dual PCI IDE Controller
14	Primary IDE Controller (dual FIFO)
15	Intel 82371AB/EB PCI Bus Master IDE Controller
15	Secondary IDE Controller (dual FIFO)

1.2.11 DMA Channel

Setting	Hardware using the setting
01	IrDA V3.0 Fast Infrared Port
02	Standard Floppy Disk Controller
03	ECP Printer Port (LPT1)
04	Direct memory access controller

1.2.12 System LED Indicator

- 4 Num-lock (on/off)
- 4 Cap-lock (on/off)
- 4 Scroll-Lock (on/off)
- 4 FDD (on/off)
- 4 HDD (on/off)
- 4 CDROM (on/off)
- 4 Power (on/off)

When the system is powered on, the Power LED will be lighted on.

When 'Battery Low Warning' occurs, the Power LED will flash at a rate of 1 time every 16 second.

When 'Battery Very Low Warning' occurs, the Power LED will flash at a rate of 1 time every 4 seconds if there is no 'Suspend to Disk' partition in the hard disk.

- 4 Charge (flash/off): Will be flashing when the battery pack is being charged.

1.2.13 Hot Key:

Key combination	Function
Fn + F1	Standby Mode
Fn + F3	Mute battery warning beep
Fn + F4	Toggle LCD / CRT display
Fn + F5	Volume increase
Fn + F6	Volume decrease
Fn + F7	Brightness up
Fn + F8	Brightness down
Fn + F9	Contrast up (for DSTN LCD)
Fn + F10	Contrast down(for DSTN LCD)

Notebook PC Service Manual

Model: 340S2

Chapter 2

Connectors and Switches

UNIWILL COMPUTER CORP.

No. 24 Pei Yuan Road
Chung Li Industrial Park, Chung Li City
Tao Yuan Hsien, Taiwan,
R.O.C.
TEL: 886-3-461-6000
FAX: 886-3-461-6317
URL: [http:// www.uniwill.com.tw/](http://www.uniwill.com.tw/)

2.1 Connector Definitions

2.1.1 Memory DIMM144 Connector (CN7 and CN6)

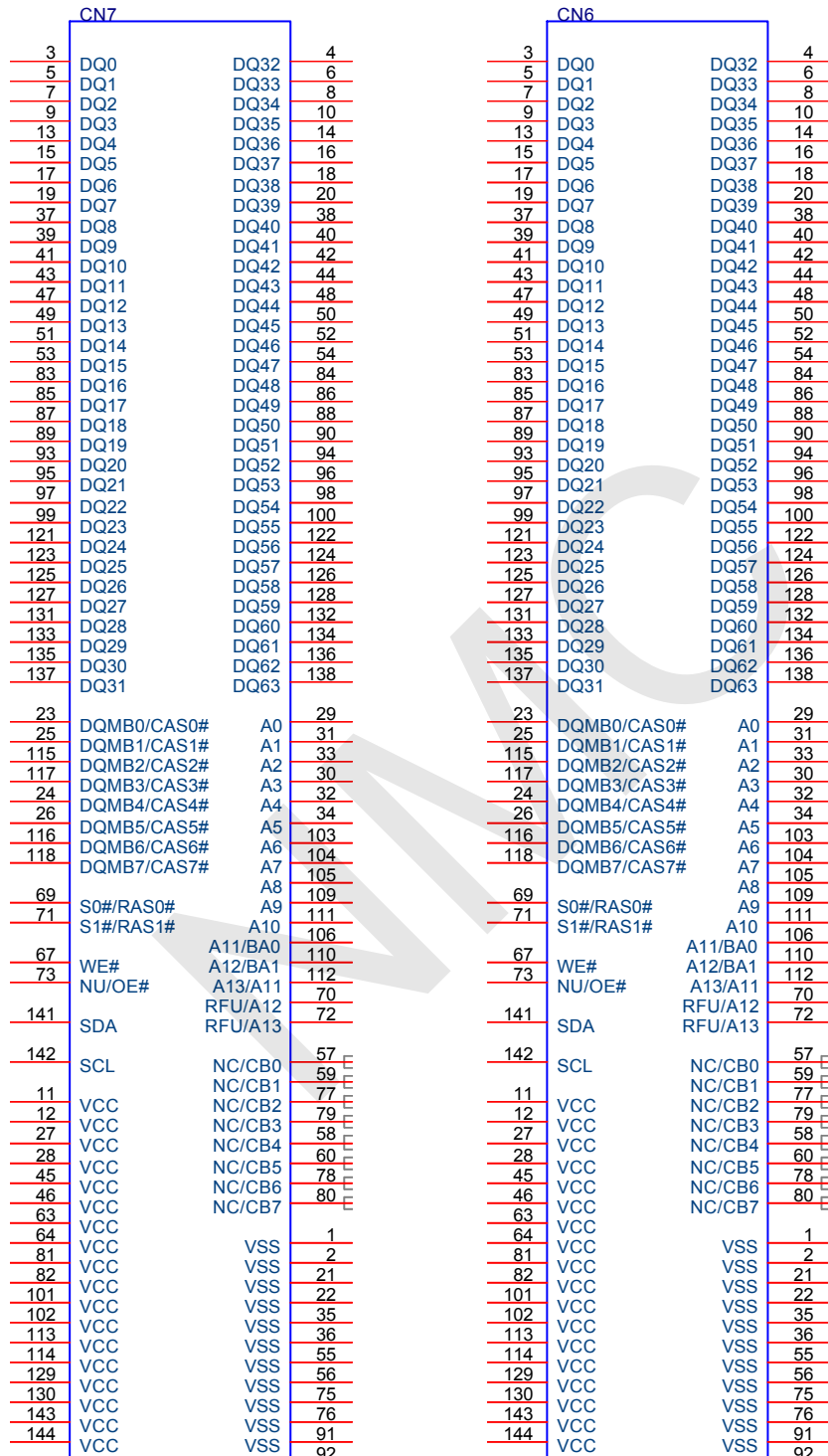

2.1.2 Modem/B Connector (CN29)

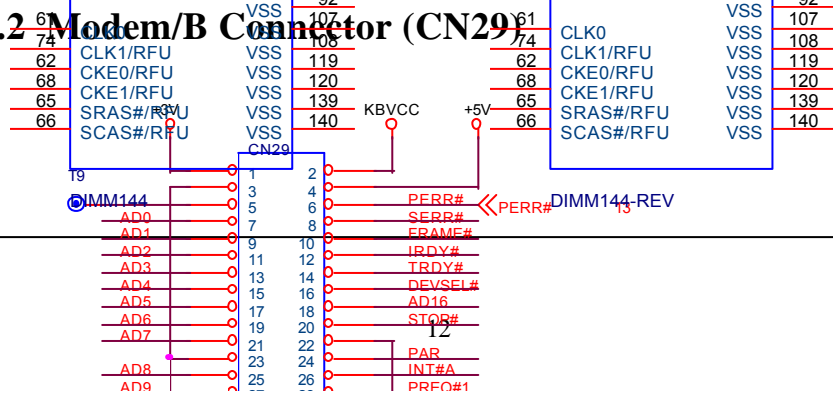

2.1.3 LCD Connector (CN4)

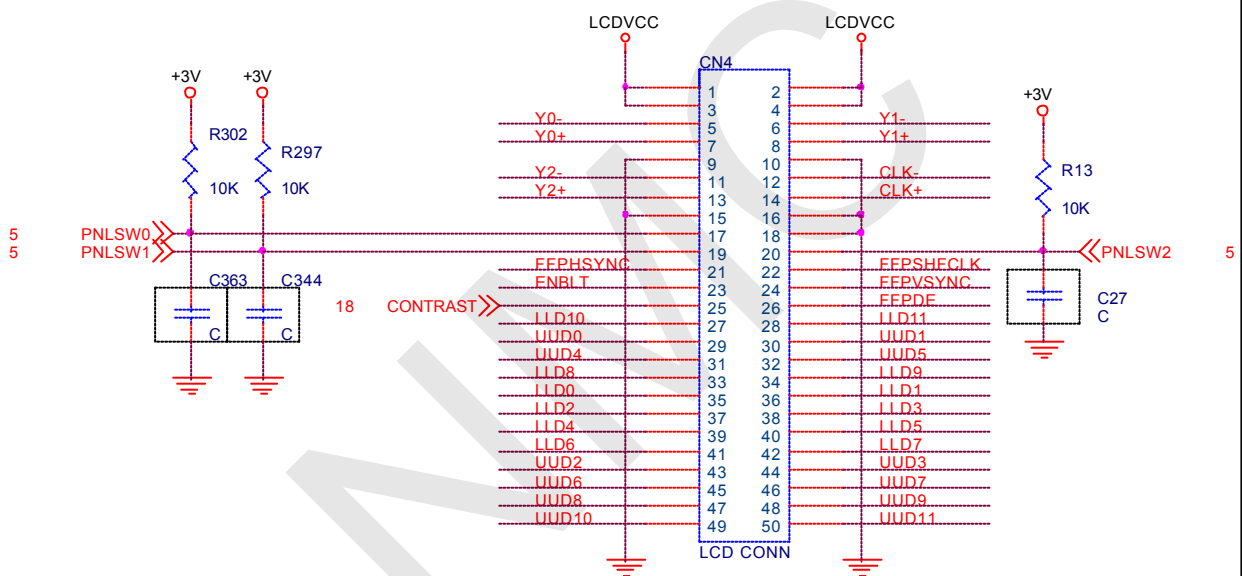

2.1.4 Inverter Connector (CN3)

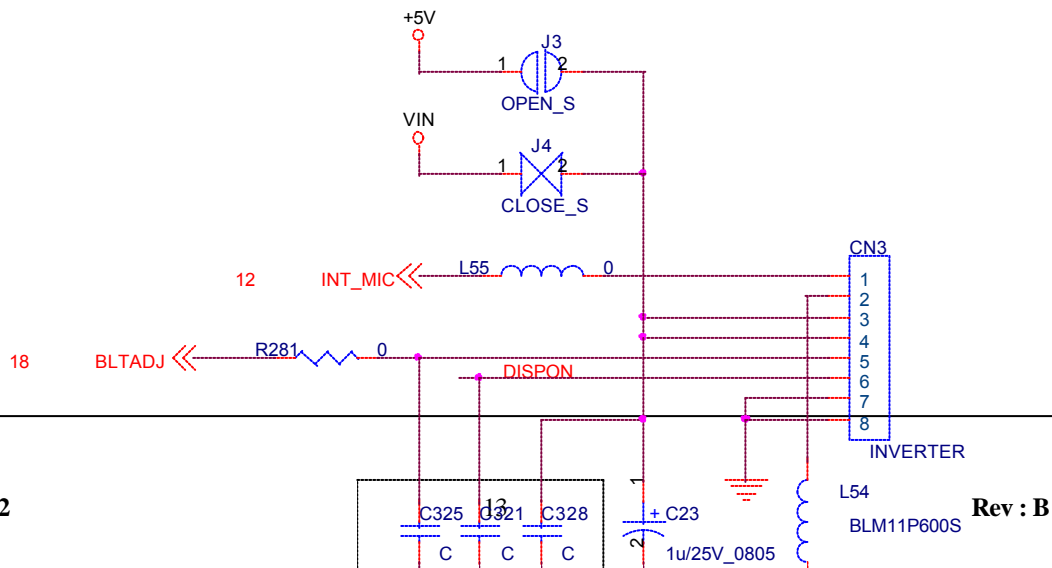

2.1.5 CRT Connector (CN20)

Pin	Description	Pin	Description
1	RED	9	+5V
2	GREEN	10	GND
3	BLUE	11	NC-
4	NC	12	DDCCLK
5	GND	13	HSYNC
6	DACGND	14	VSYNC
7	DACGND	15	DDCDATA
8	DACGND		

2.1.6 USB Connector (CN21)

Pin	Description
1	+5V
2	USBP0-
3	USBP0+
4	GND

2.1.7 RJ45 (CN15)

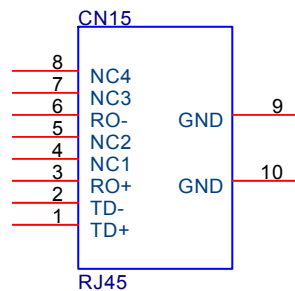

2.1.8 RJ11 (CN16)

Pin	Description
1	HRTXRPN
2	HRTXRXP

2.1.9 Modem Phone (CN17) and Modem Connector (CN23)

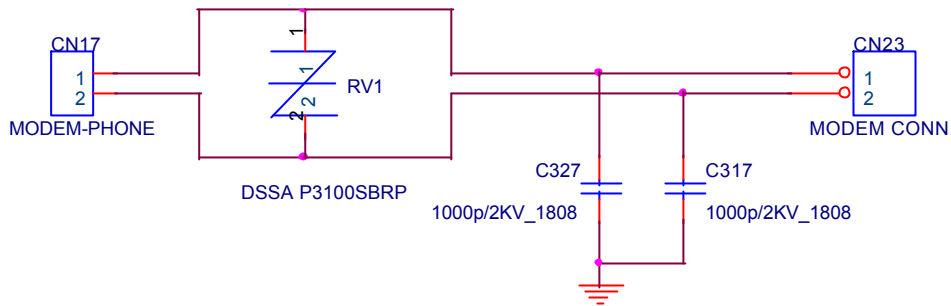

2.1.10 MDC Connector (CN26)

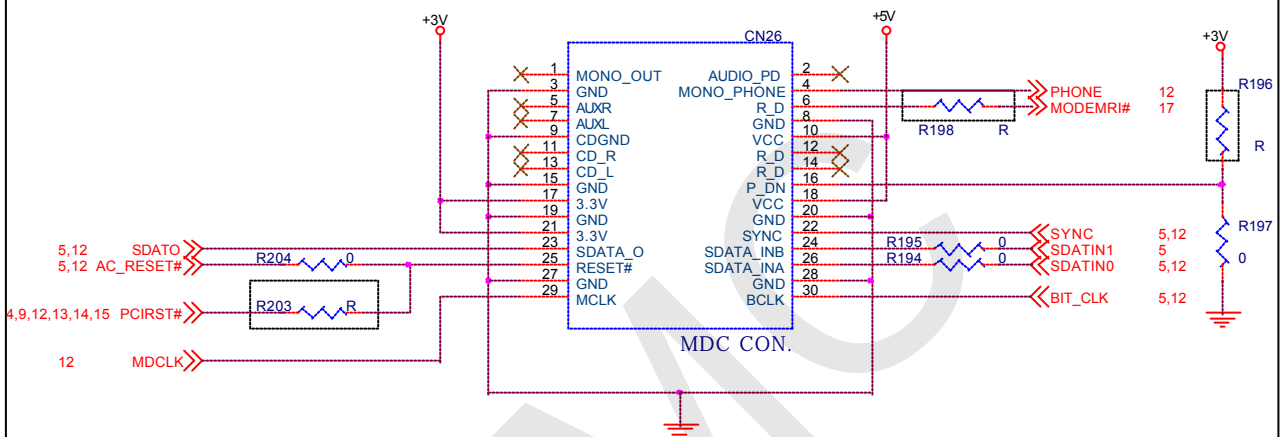

2.1.11 MIC Jack (CN13)

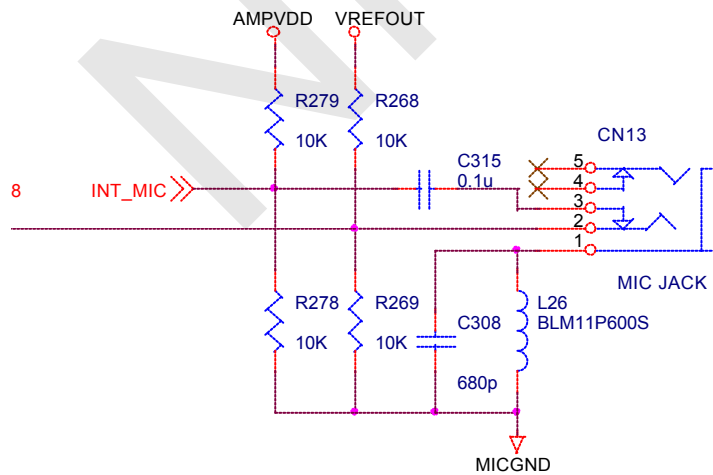

2.1.12 Speaker Jack (CN12)

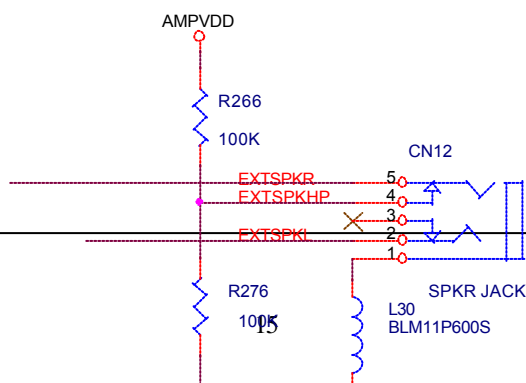

2.1.13 R/L Speaker Connector (CN5)

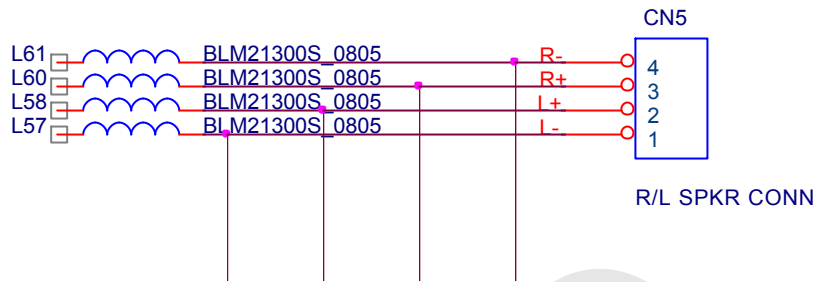

2.1.14 PCMCIA Connector (CN28)

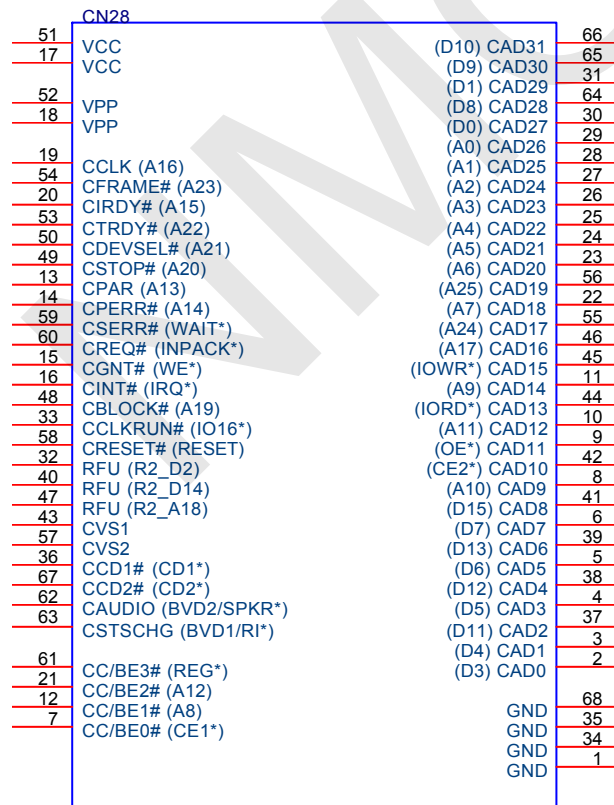

PCMCIA CONN

2.1.15 HDD Connector (CN27)

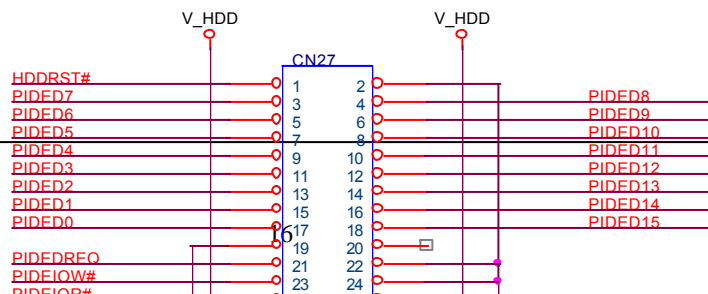

2.1.16 CDROM Connector

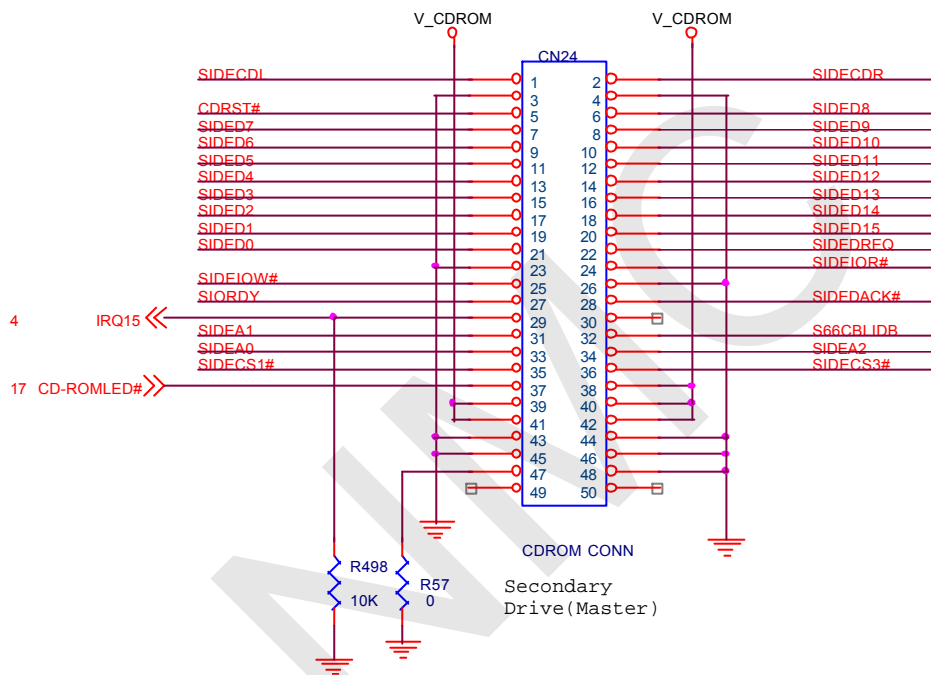

2.1.17 FDD Connector (CN10)

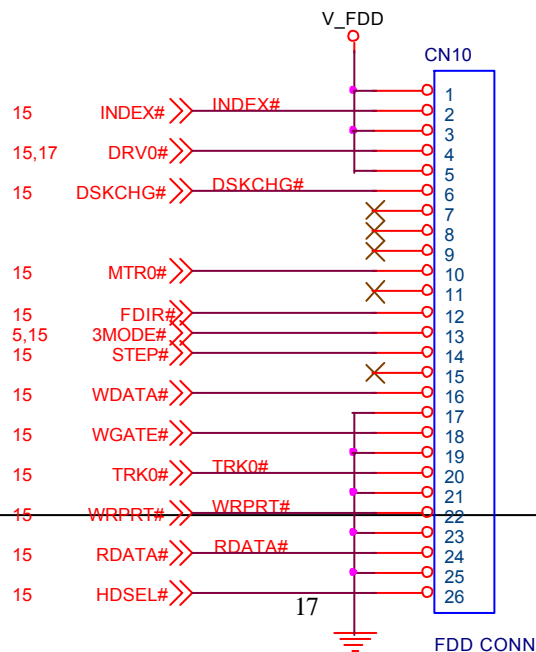

NMNC

2.1.18 Parallel Connector (CN18)

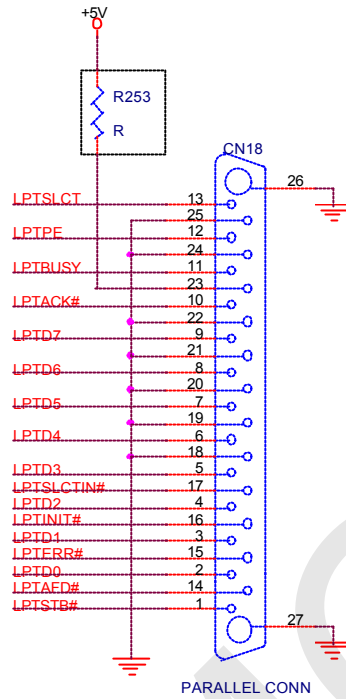

2.1.19 Serial Connector (CN19)

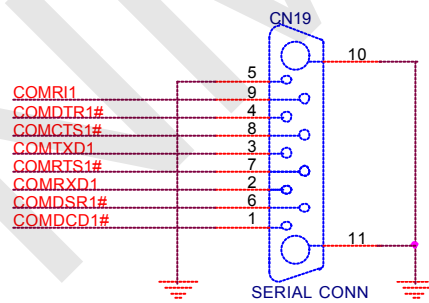

2.1.20 LID Connector (CN1)

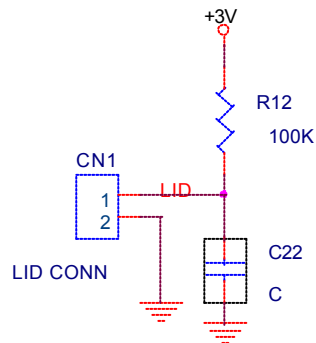

2.1.21 Internal KB Connector (CN9)

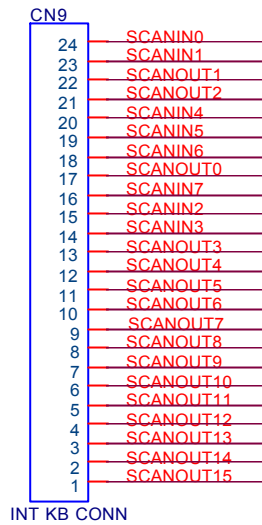

2.1.22 Test Connector (CN8)

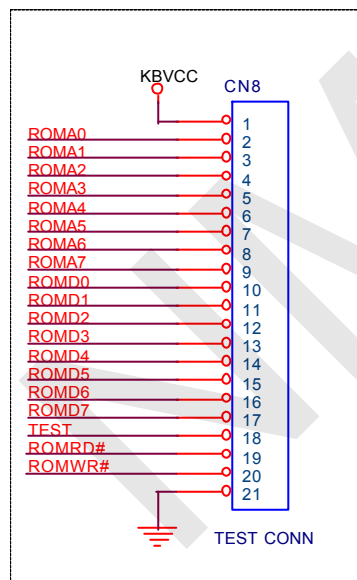

2.1.23 Fan2 Connector (CN2)

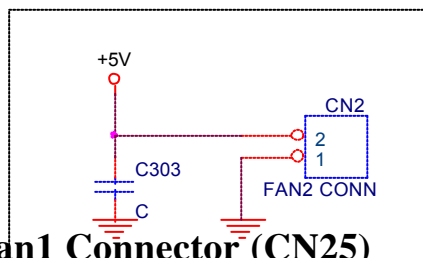

2.1.24 Fan1 Connector (CN25)

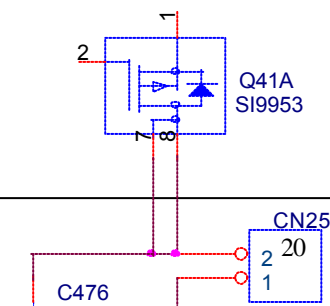

2.1.25 PS2 Connector (CN14)

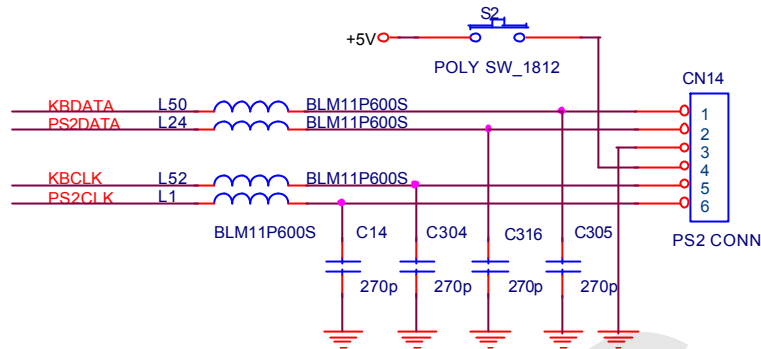

2.1.26 Power Switch (SW2)

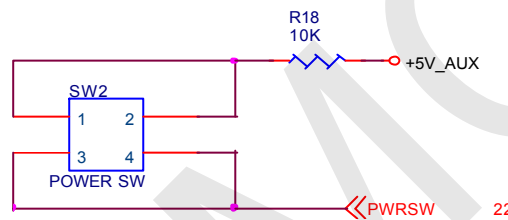

2.1.27 AC Connector (CN22)

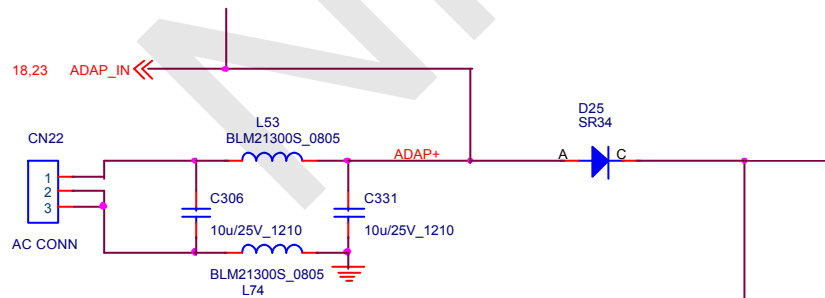

2.1.28 Battery Connector (CN30)



Pin No.	Pin Name
1	BATT+
2	SMBCLK
3	SMBDATA
4	TEMP
5	+5V_AUX
6	GND
7	NC
8	NC

2.1.29 Touch Pad Connector (CN11)

Pin No.	Pin Name
1	PSCLK3
2	PSDAT3
3	GND
4	NC
5	+5V
6	NC

2.1.30 But_SW_0 (SW1)

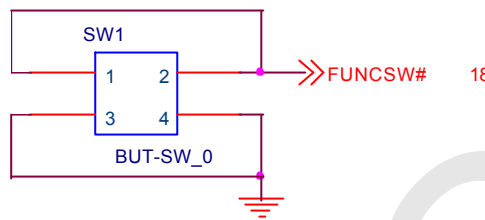

2.2 Mechanical Buttons and Switch Definition

2.2.1 Power on/off button

1. If the system is in S0, S1 or S2 state, pressing the power button will transit the system to S4 (Suspend to Disk), S5 (Soft-off) state depending on the “Power button function” setting in the BIOS Setup menu.
2. If the system is in S4 or S5 state, pressing the power button will awaken the system into S0 state.
3. If the power button is pressed for more than four seconds, a power button over-ride event is generated and the system will be put into S5 (Soft-off) state.

2.2.2 Cover (Lid) Switch

When LCD cover is closed, this Lid switch is triggered and an SMI/SCI is generated to put the system into ‘Suspend to RAM’ or ‘Suspend to Disk’ mode depending on the “Cover Switch” setting in the BIOS Setup menu.

2.2.3 WWW function button

When this button is pressed, the system will launch Microsoft Internet Explorer and connect to default setting of Internet Explorer.

2.2.4 CPU DIP Switch Settings (SW7 – near CPU socket)

SW7 (For Celeron and Pentium III)					
1	2	3	4	CPU	SDRAM
ON	OFF	OFF	OFF	66M	66M
OFF	OFF	OFF	OFF	66M	100M
OFF	OFF	OFF	ON	100M	100M

Note: SW7-5, 6, 7, 8: Always OFF

Celeron		
Processor	System Bus Frequency(MHz)	L2 Cache Size(Kbytes)
500	66	128
533	66	128
566	66	128
600	66	128

Pentium III		
Processor	System Bus Frequency(MHz)	L2 Cache Size(Kbytes)
500	100	256
550E	100	256
600E	100	256
650	100	256
700	100	256
750	100	256
800	100	256
850	100	256

2.3. Major Components and Connectors Location

2.3.1 Bottom Side

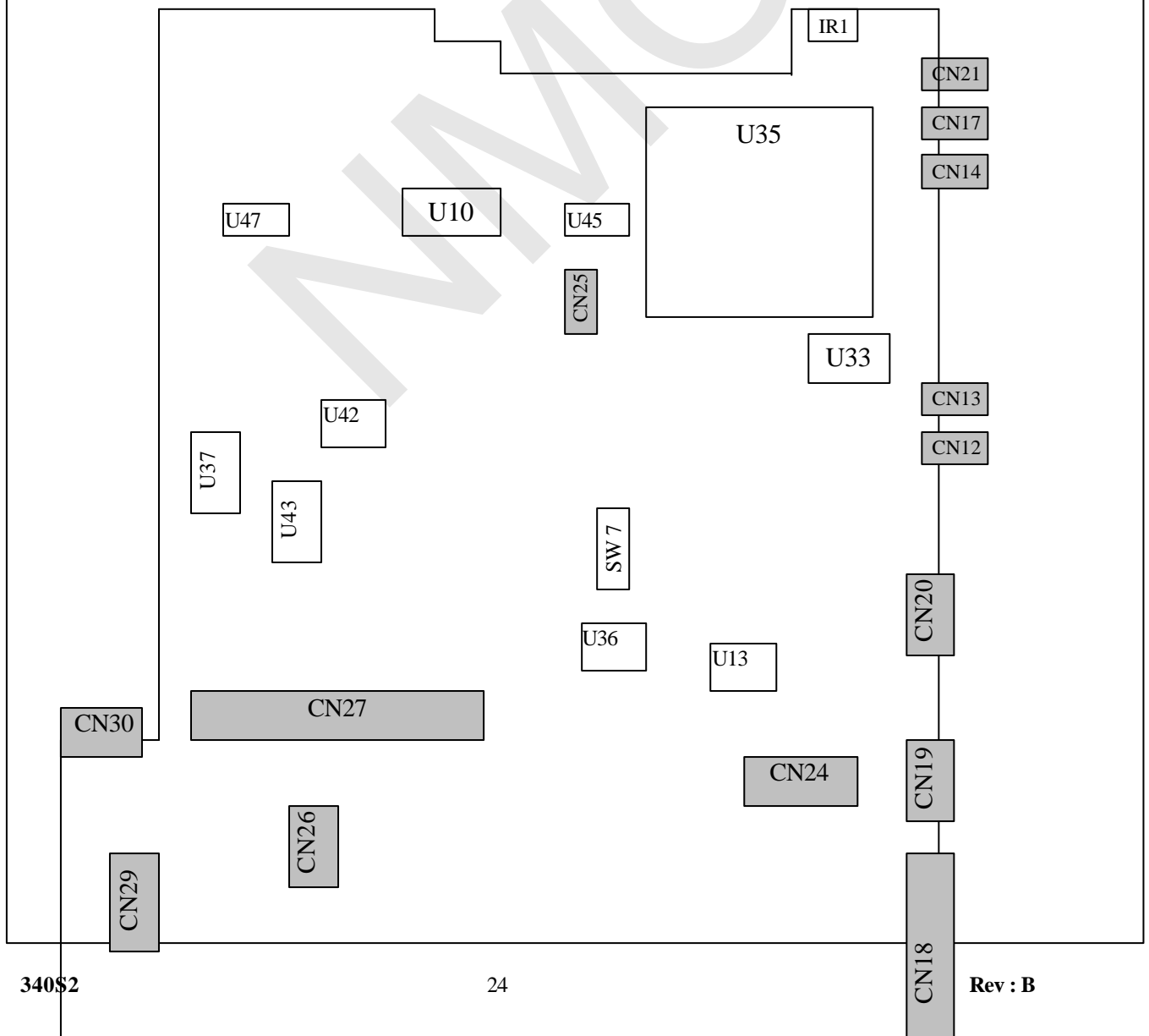

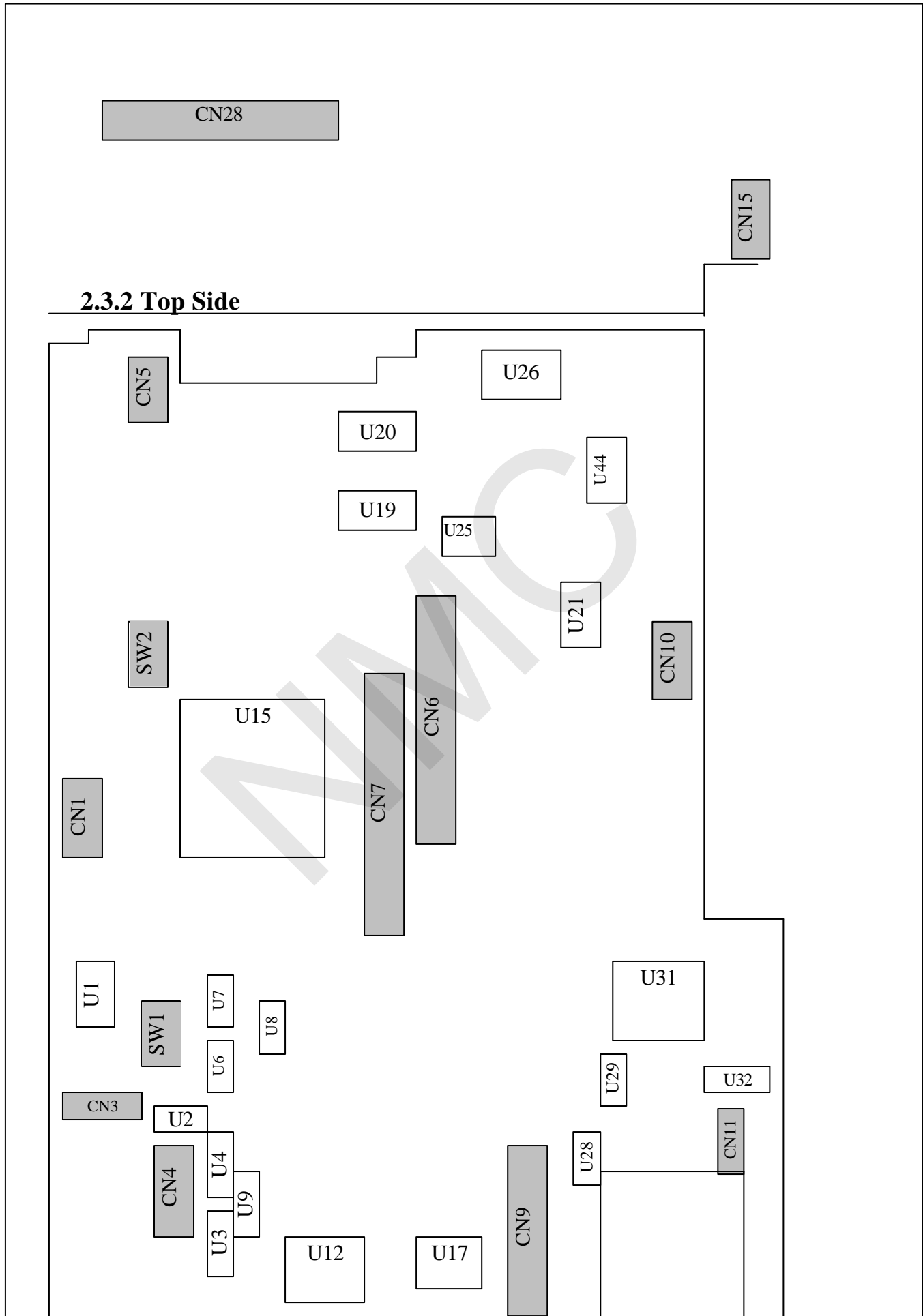

2.3.2 Top Side

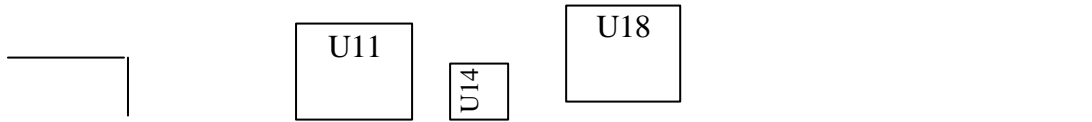

Notebook PC Service Manual

Model : 340S2

Chapter 3 Major Components

UNIWILL COMPUTER CORP.

No. 24 Pei Yuan Road
Chung Li Industrial Park, Chung Li City
Tao Yuan Hsien, Taiwan,
R.O.C.
TEL: 886-3-461-6000
FAX: 886-3-461-6317
URL: [http:// www.uniwill.com.tw/](http://www.uniwill.com.tw/)

3.1 Major Component List

Reference	Description	Vendor	Component Name
U1	RS-232 TRANSCEIVER	ANALOG	ADM213
U2	P-MOSFET FOR LCD VCC	CET	9424 SO-8
U3	1MX16 VRAM	-	NT56V1616A0T
U4	LVDS PANEL TRANSMITTER	TI	SN75LVDS84
U6	NOT GATE	TI	74LVC14
U7	AND GATE	PHILIPS	74LVC08
U8	OR GATE	-	74LVC32
U9	4MX16 VRAM	HYUNDAI	M12L1616A_7T
U10	CLOCK GENERATOR	WINBOND	ICS9248-126
U11	SUPER I/O CONTROLLER	NS	PC87393
U12	DSTN CONTROLLER	NS	CS9211
U13	SERIAL ROM FOR LAN	ATMEL	93C46
U14	SWITCH	TI	74LVC373
U15	CORE LOGIC	SIS	SIS630
U17	BIOS EEPROM SOCKET	UNICORN	29LV020(PLCC-32)
U18	KB CONTROLLER	NS	PC87570
U19	PWM CONTROL	TI	TL594-SOP16
U20	STEP DOWN DC-DC CONVERTER	TOYOTA	SB3060P-SSOP24
U21	LOW DROPOUT REGULATOR	ALPHA	AS2951
U24	ZENER SHUNT REGULATOR	ZETEX	ZR431
U25	AC'97 AUDIO CODEC	AVANCE	AVANCE_ALC100
U26	AUDIO AMPLIFIER	NS	LM4835
U28	RAM SWITCH	PHILIPS	74HCT4066
U29	PCMCIA POWER CONTROLLER	MICREL	MIC2562A
U31	PCMCIA CONTROLLER	O2Micro	OZ6812
U32	OP AMP.	NS	LM358
U33	TEMPERATURE SENSOR	AD	ADM1021
U35	PPGA CPU SOCKET	SKT	SOCKET 370
U36	OCTAL BUFFER	PHILIPS	74VLC244
U37	PWM CONTROL	TI	TL594
U42	LINEAR REGULATOR	NS	78L12
U43	STEP DOWN DC-DC CONVERTER	SMD	SB3052P
U44	PWM CONTROL	TI	TL594
U45	LOW DROPOUT REGULATOR	OMA	AME8800DEFT
U47	LOW DROPOUT REGULATOR	OMA	AME8800AEFT
IR1	IR TRANSCEIVER MODULE	STANLEY	HRM230S

3.2 Major Components Pin Assignment

1.1.1.1.1.SOCKET 370 _A

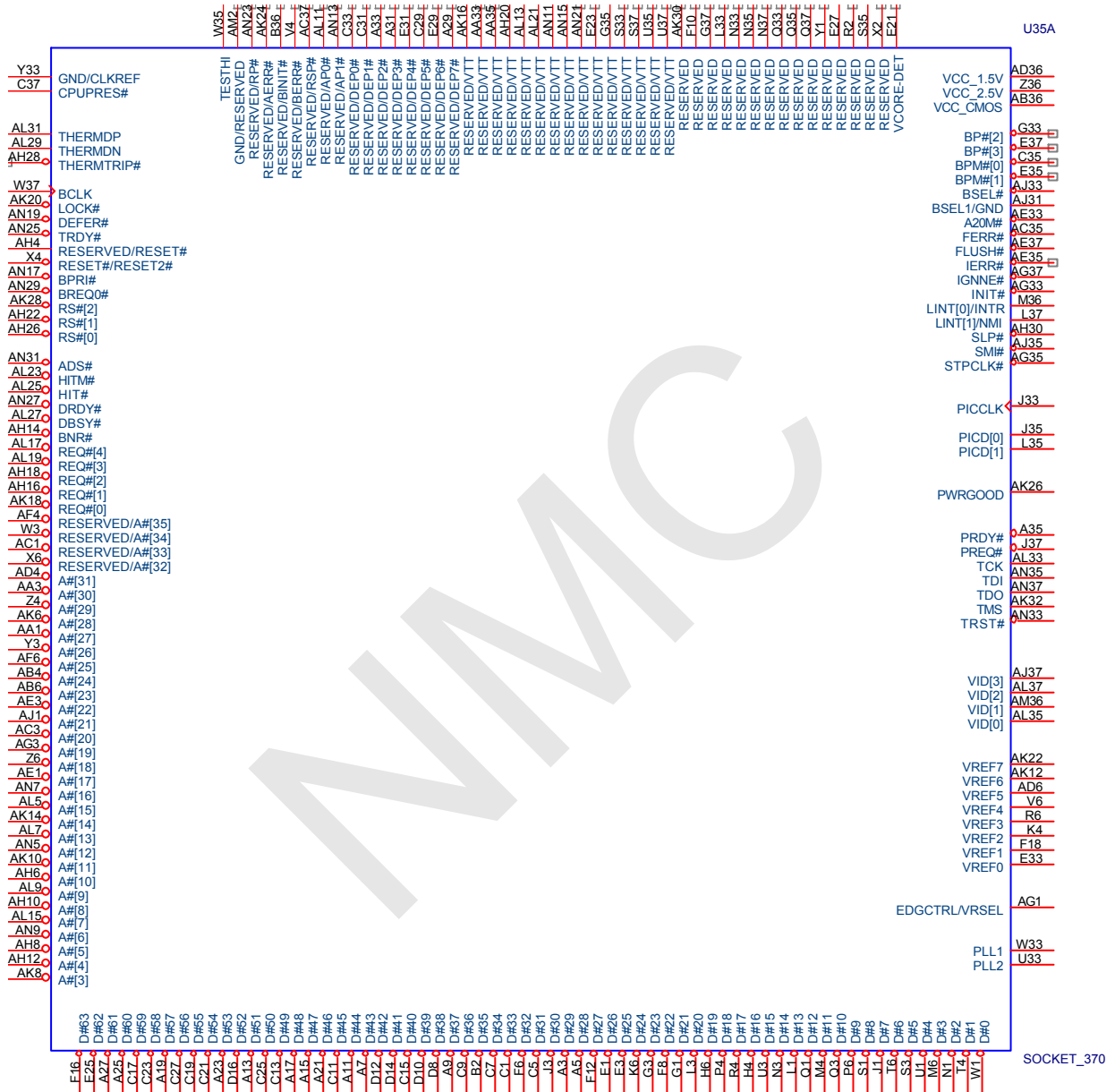

1.1.1.1.2. SOCKET 370 B

U35B

AA37	VCC_CORE	GND	A37
AA5	VCC_CORE	GND	AB32
AB2	VCC_CORE	GND	AC33
AB34	VCC_CORE	GND	AC5
AD32	VCC_CORE	GND	AD2
AE5	VCC_CORE	GND	AD34
AF2	VCC_CORE	GND	AF32
AF34	VCC_CORE	GND	AF36
AH24	VCC_CORE	GND	AG5
AH32	VCC_CORE	GND	AH2
AH36	VCC_CORE	GND	AH34
AJ13	VCC_CORE	GND	AJ11
AJ17	VCC_CORE	GND	AJ15
AJ21	VCC_CORE	GND	AJ19
AJ25	VCC_CORE	GND	AJ23
AJ29	VCC_CORE	GND	AJ27
AJ5	VCC_CORE	GND	AJ3
AJ9	VCC_CORE	GND	AJ7
AK2	VCC_CORE	GND	AK36
AK34	VCC_CORE	GND	AK4
AM12	VCC_CORE	GND	AL1
AM16	VCC_CORE	GND	AL3
AM20	VCC_CORE	GND	AM10
AM24	VCC_CORE	GND	AM14
AM28	VCC_CORE	GND	AM18
AM32	VCC_CORE	GND	AM22
AM4	VCC_CORE	GND	AM26
AM8	VCC_CORE	GND	AM30
B10	VCC_CORE	GND	AM34
B14	VCC_CORE	GND	AM6
B18	VCC_CORE	GND	AN3
B22	VCC_CORE	GND	B12
B26	VCC_CORE	GND	B16
B30	VCC_CORE	GND	B20
B34	VCC_CORE	GND	B24
B6	VCC_CORE	GND	B28
C3	VCC_CORE	GND	B32
D20	VCC_CORE	GND	B4
D24	VCC_CORE	GND	B8
D28	VCC_CORE	GND	D18
D32	VCC_CORE	GND	D2
D36	VCC_CORE	GND	D22
D6	VCC_CORE	GND	D26
E13	VCC_CORE	GND	D30
E17	VCC_CORE	GND	D34
E5	VCC_CORE	GND	D4
E9	VCC_CORE	GND	E11
F14	VCC_CORE	GND	E15
F2	VCC_CORE	GND	E19
F22	VCC_CORE	GND	E7
F26	VCC_CORE	GND	F20
F30	VCC_CORE	GND	F24
F34	VCC_CORE	GND	F28
F4	VCC_CORE	GND	F32
H32	VCC_CORE	GND	F36
H36	VCC_CORE	GND	G5
J5	VCC_CORE	GND	H2
K2	VCC_CORE	GND	H34
K32	VCC_CORE	GND	K36
K34	VCC_CORE	GND	L5
M32	VCC_CORE	GND	M2
N5	VCC_CORE	GND	M34
P2	VCC_CORE	GND	P32
P34	VCC_CORE	GND	P36
R32	VCC_CORE	GND	Q5
R36	VCC_CORE	GND	R34
S5	VCC_CORE	GND	T32
T2	VCC_CORE	GND	T36
T34	VCC_CORE	GND	U5
V32	VCC_CORE	GND	V2
V36	VCC_CORE	GND	V34
W5	VCC_CORE	GND	X32
X34	VCC_CORE	GND	X36
Y35	VCC_CORE	GND	Y37
Z32	VCC_CORE	GND	Y5
		GND	Z2
		GND	Z34
		GND	

SOCKET 370

SIS 630 Host and Memory (U15A)

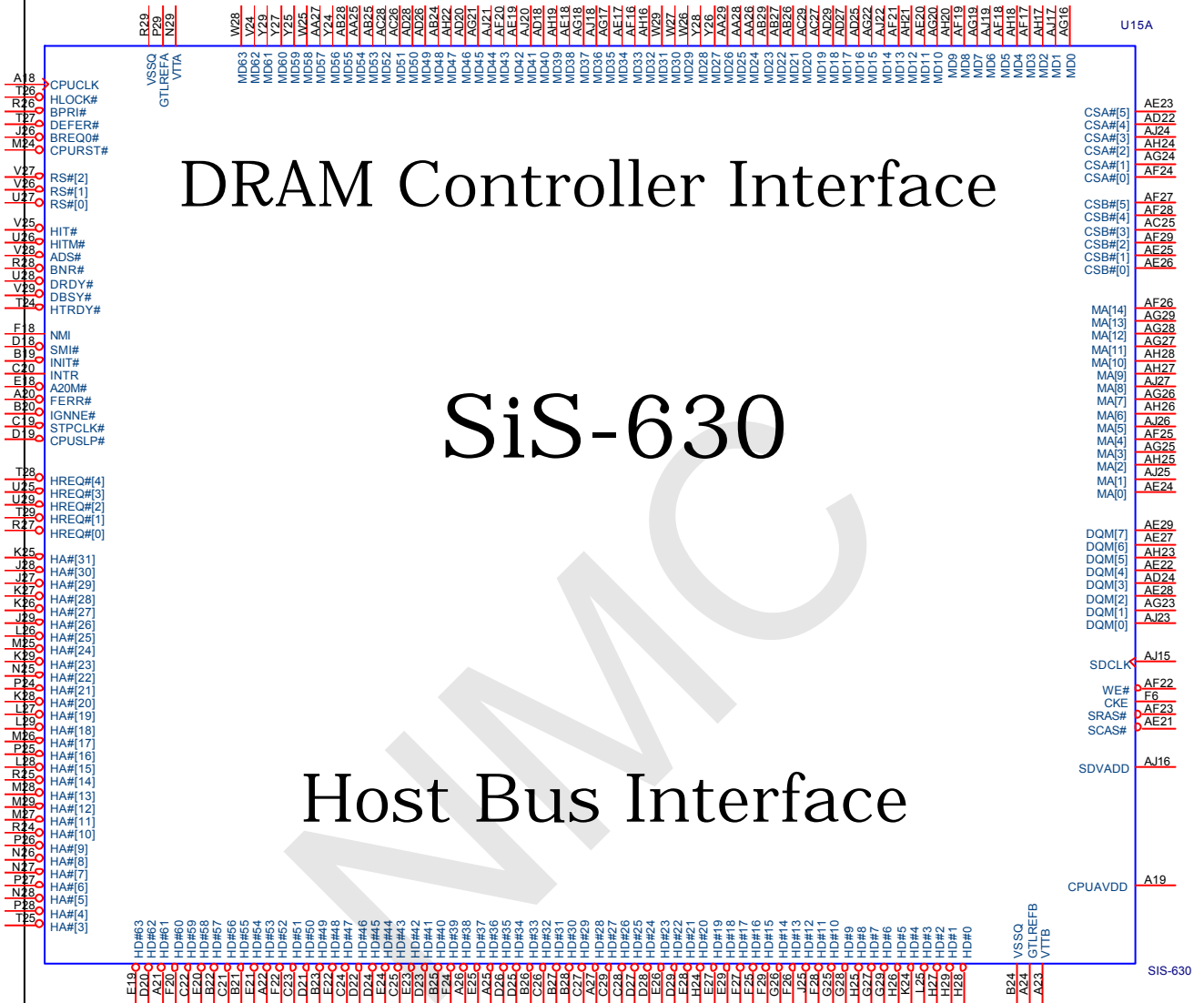

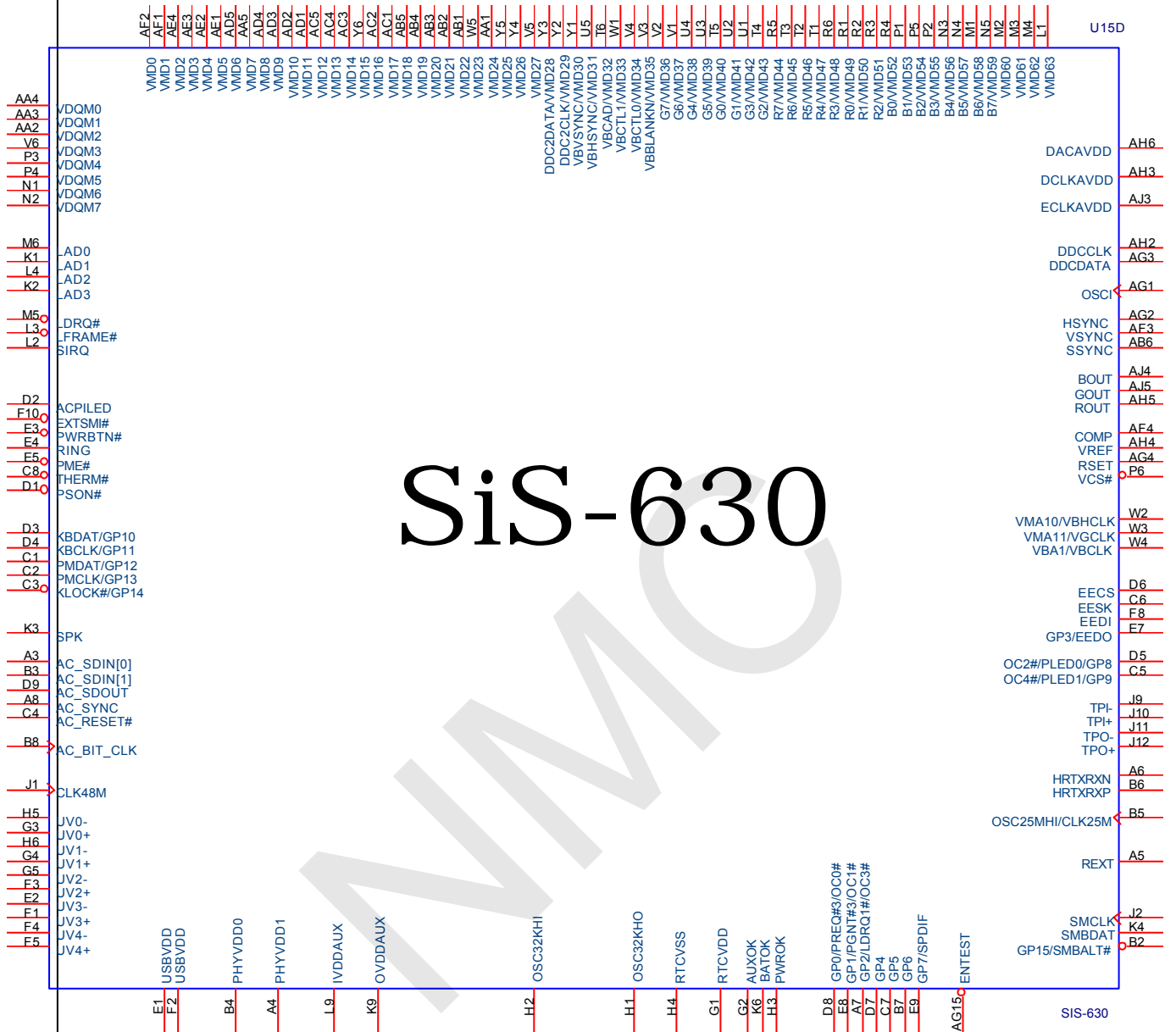

SiS-630

Clock Generator (U10)

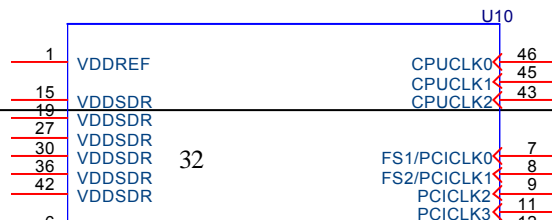

SN75LVDS84

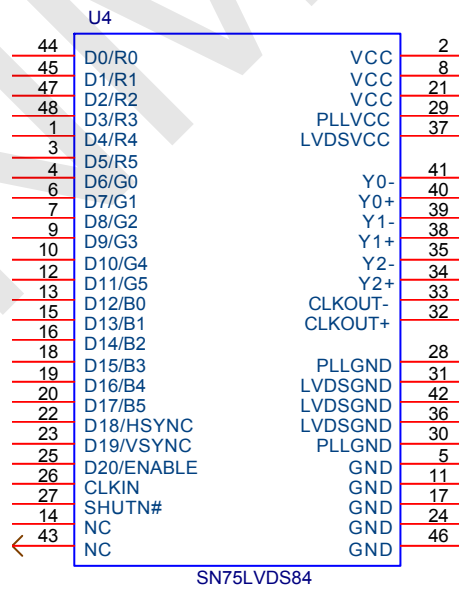

CS9211 (U12)

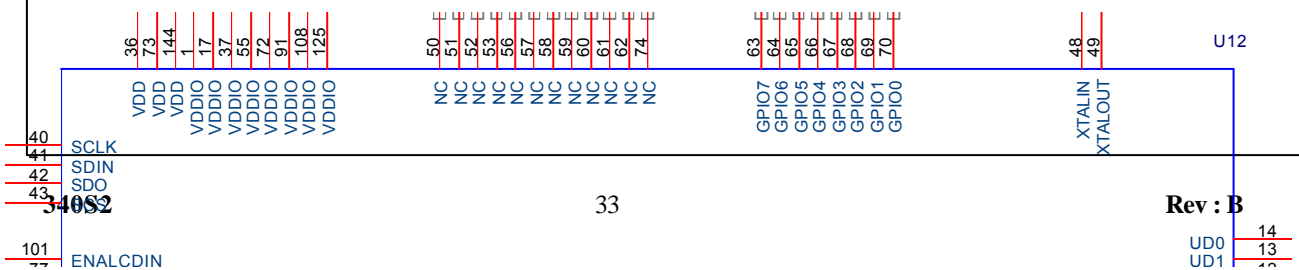

NMNC

NT56V1616A0T
SSM2165_SO8

M12L1616A_7T

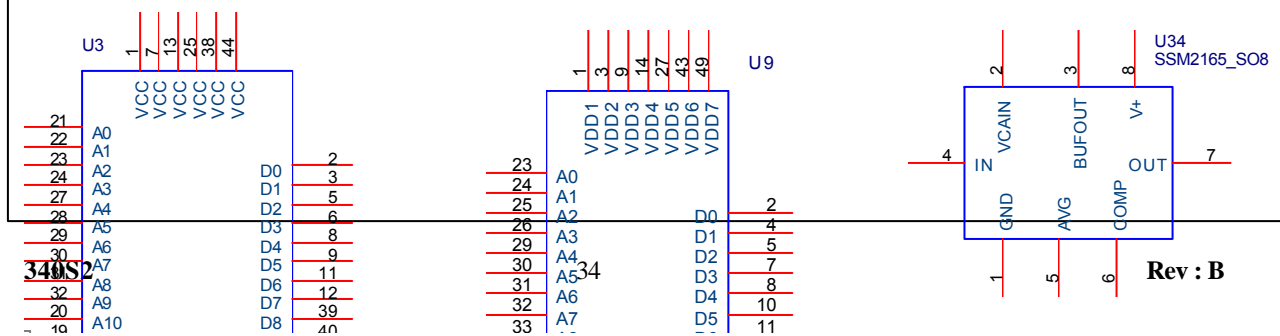

Rev : B

20VZ11 (U27)

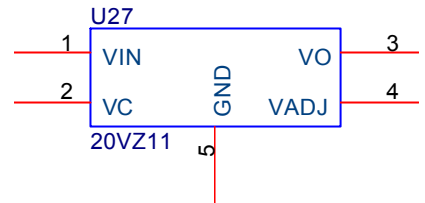

CODEC (U25) LM4835 (U26)

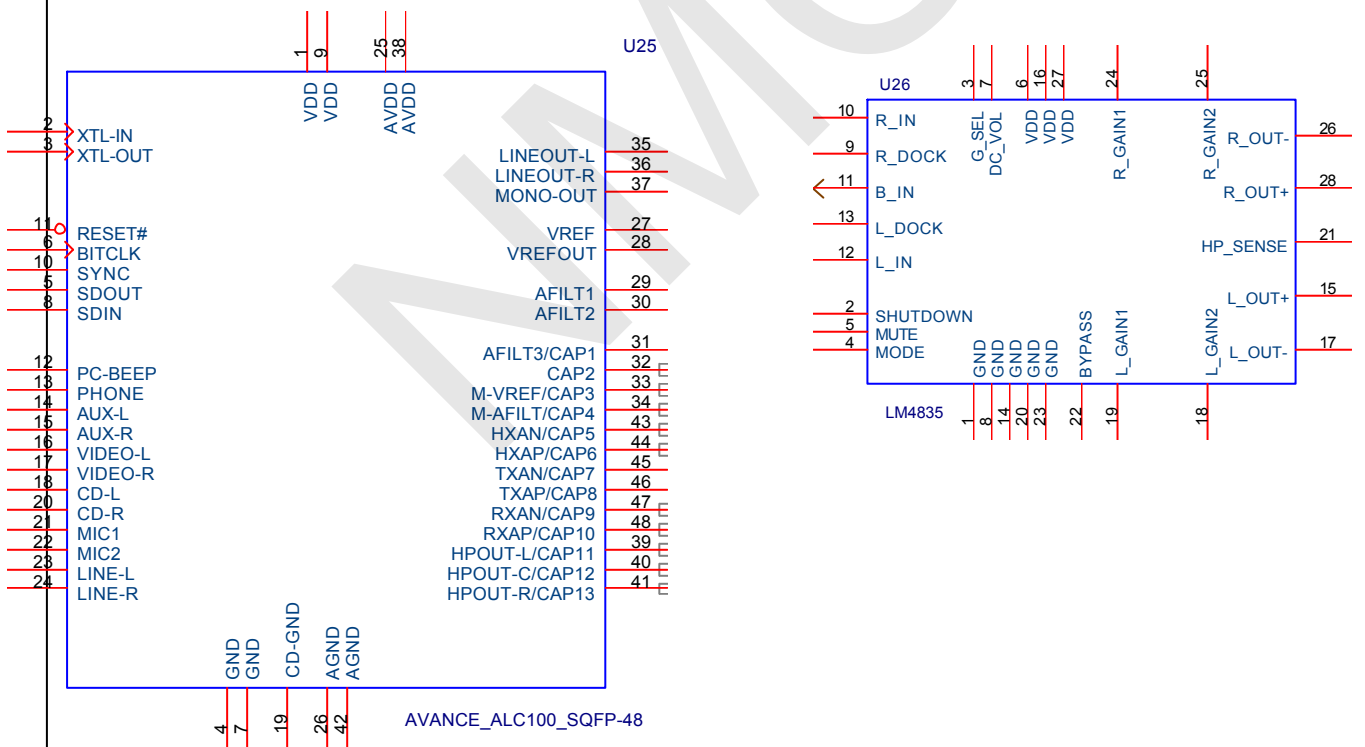

PCMCIA Controller O2Micro OZ6812 MIC2562A (U29)

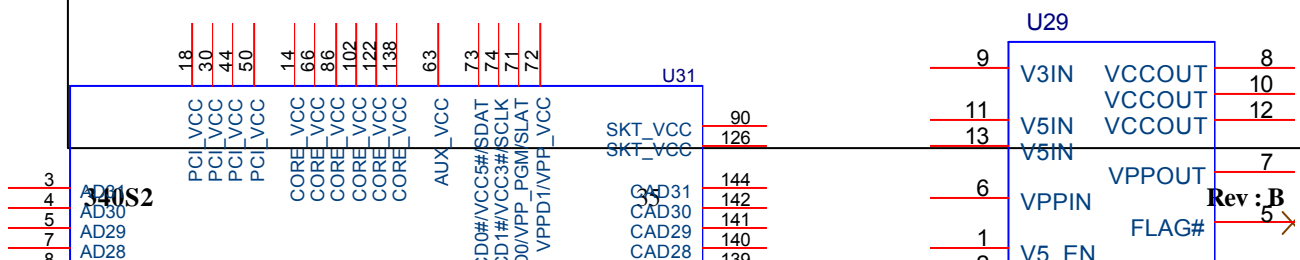

74LVC373 (U14)

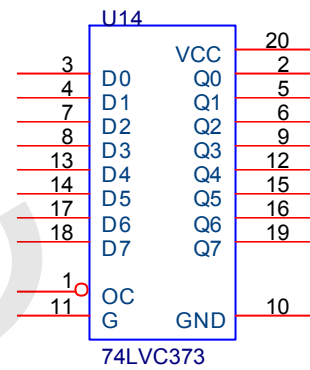

Super I/O Controller (PC87393)
(HRM230S)

IR

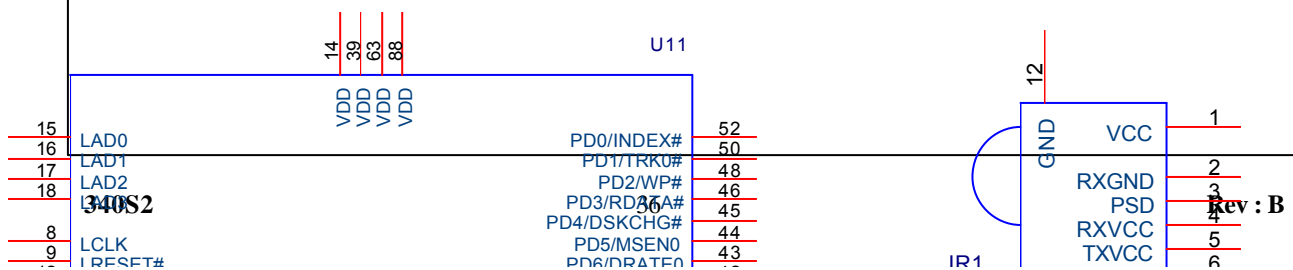

ADM213 (U1)

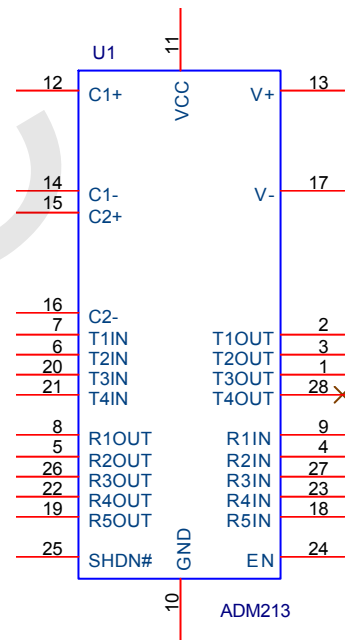

Keyboard Controller PC87570

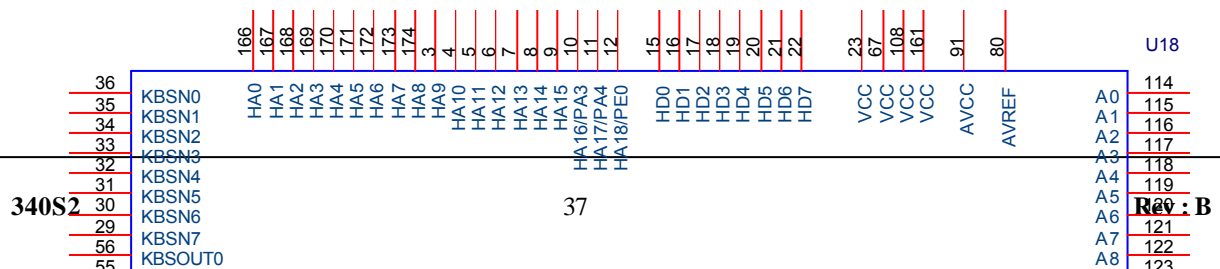

NMMC

SB3052P	TL594	29LV020
---------	-------	---------

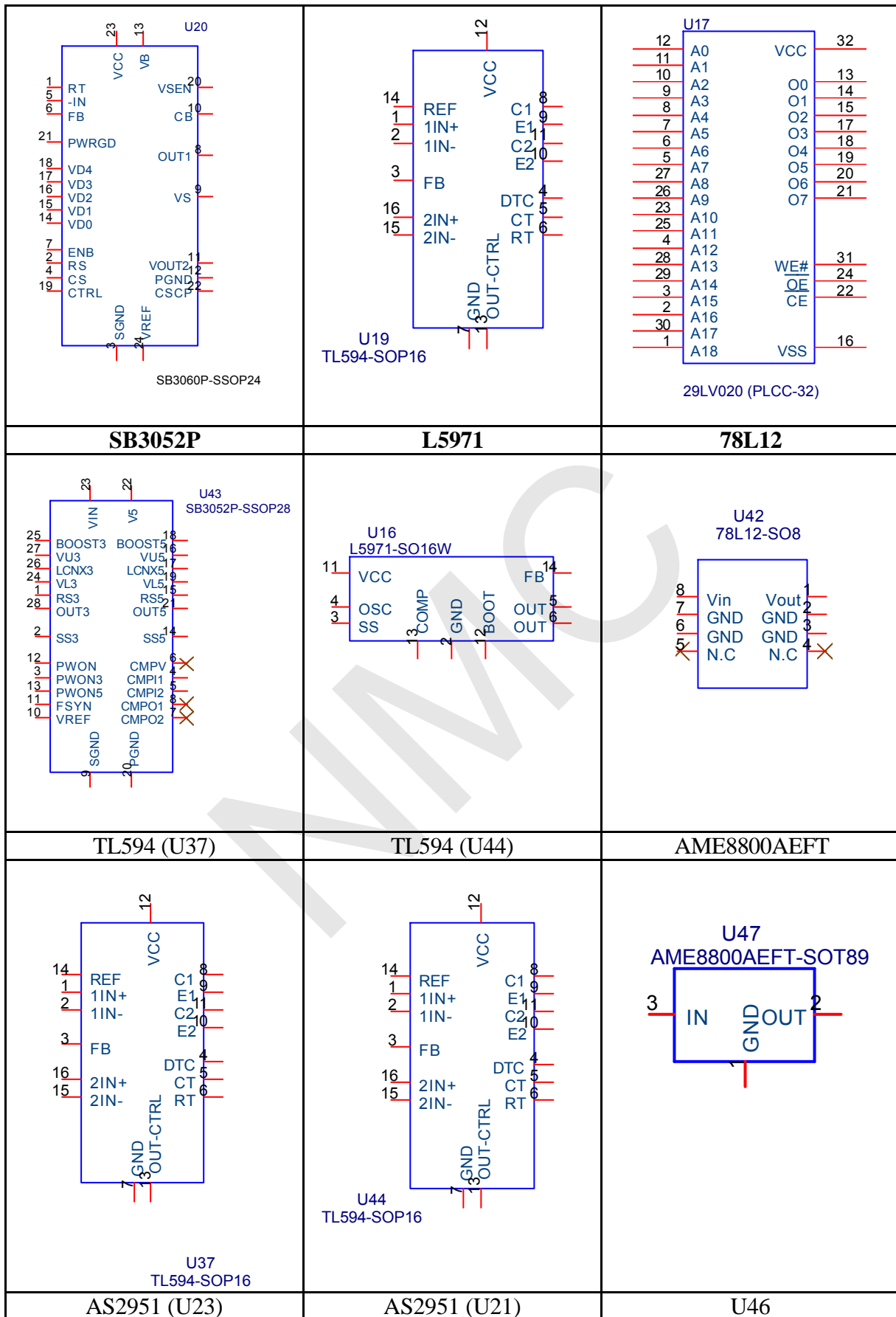

<p>U23 AS2951_SO8</p>	<p>U21 AS2951_SO8</p>	<p>U46 ADM1021</p>
<p>LM358</p>	<p>LM358</p>	<p>ADM1021</p>
<p>U32A LM358-SO8</p>	<p>U32B LM358-SO8</p>	<p>U33 ADM1021</p>
<p>93C46</p>	<p>74HCT4066</p>	<p>74LVC244</p>
<p>U13 93C46 (CMOS_SERIALE2)</p>	<p>U28 74HCT4066</p>	<p>U36 74LVC244</p>
<p>74LVC14</p>	<p>74LVC14</p>	<p>74LVC14</p>
<p>U6A 74LVC14</p>	<p>U6B 74LVC14</p>	<p>U6C 74LVC14</p>
<p>74LVC32</p>	<p>74LVC32</p>	<p>74LVC32</p>
<p>U8C 74LVC32</p>	<p>U8A 74LVC32</p>	<p>U8B 74LVC32</p>
<p>74LVC08</p>	<p>9424</p>	<p>MAX708</p>

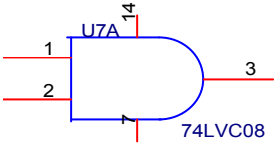
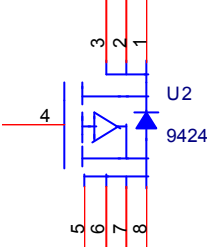
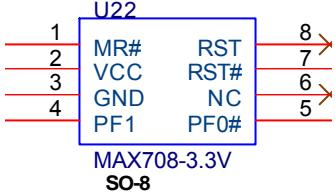
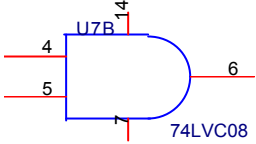
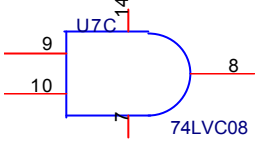
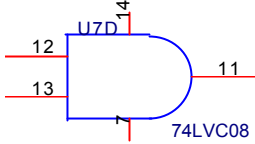
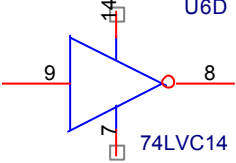
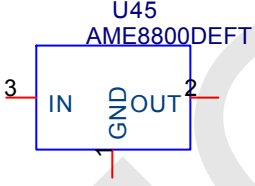
		
<p>74LVC08</p>	<p>74LVC08</p>	<p>74LVC08</p>
		
<p>74LVC14</p>	<p>AME8800DEFT</p>	
		

Notebook PC Service Manual

Model : 340S2

Chapter 4 System Disassembly

UNIWILL COMPUTER CORP.
 No. 24., Pei Yuan Road,
 Chung Li Industrial Park, Chung Li City
 Taiwan, R.O.C.
 TEL: 886-3-461-6000
 FAX: 886-3-461-8000
 URL: [http:// uniwill.com.tw/](http://uniwill.com.tw/)

System Disassembly

1. Remove LEFT HINGE and RIGHT HINGE COVERS.
2. To remove K/B, unlock the latches of the K/B.



3. Remove SCREW (#1) of HDD COVER (#2) and CPU DOOR (#3).
4. Disassemble BATTERY by unlocking the BATTERY KNOB (#4)

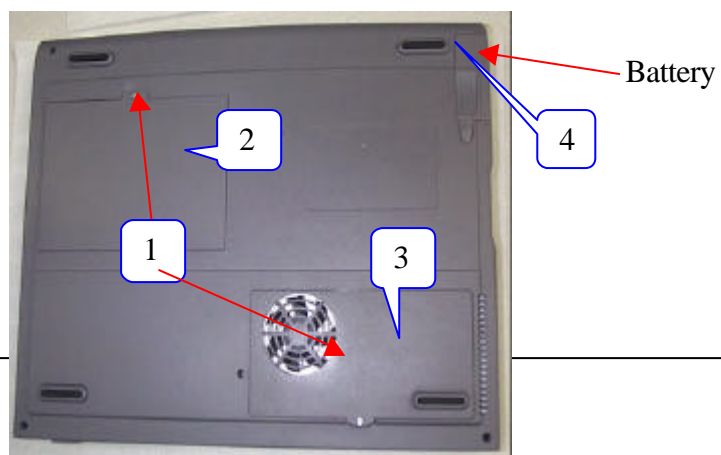

5. Unfasten SCREWS (#5) of HDD and remove HDD.

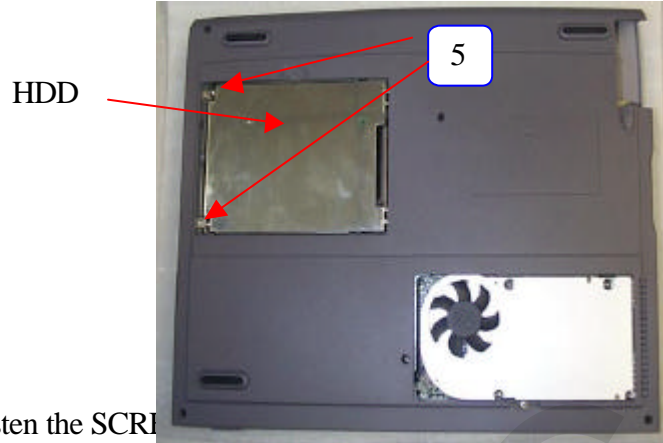

6. Unfasten the SCREWS (#6) of the FAN MODULE (#7)

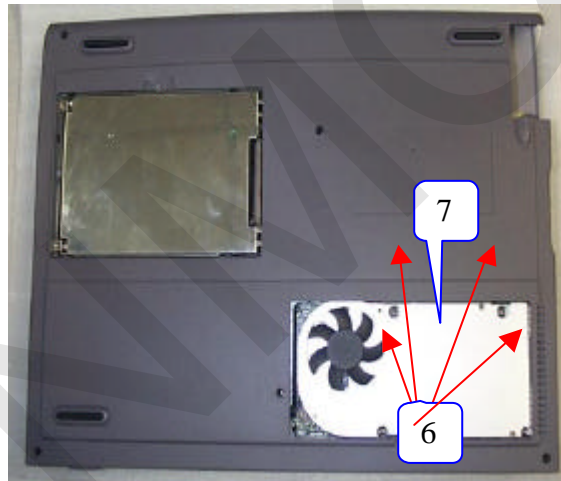

7. Unscrew the SCREWS *5 (#8) of the bottom cabinet.

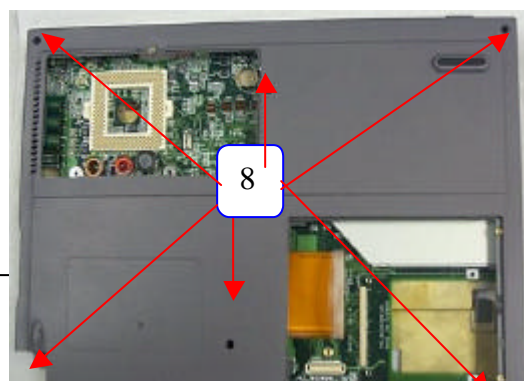

8. Remove SCREWS and disassemble TOP Cabinet Assembly (#9).

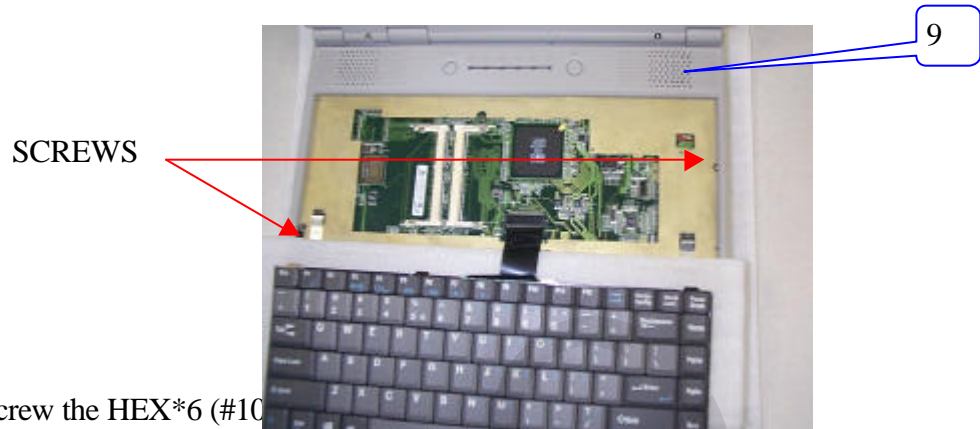

9. Unscrew the HEX*6 (#10)

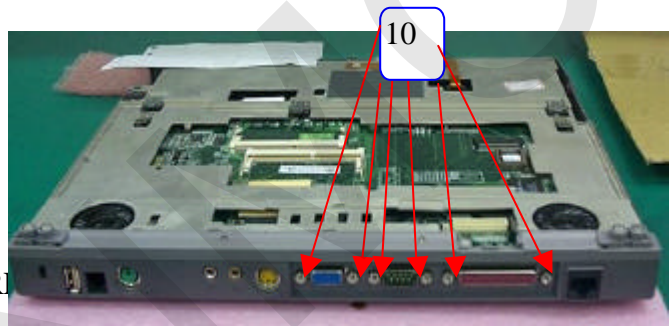

10. Unscrew SCREWS

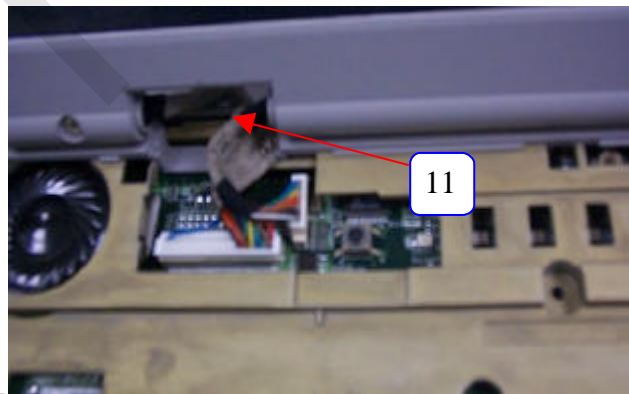

11. Disconnect LCD CABLE and INVERTER CABLE.

12. Unfasten SCREWS*4 (#12) of the HINGES and disassemble LCD MODULE.



LCD Cable
Inverter Cable

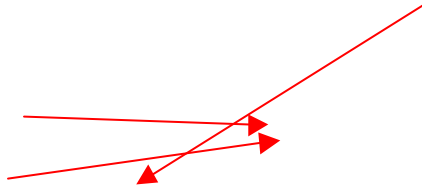

- 13. Disassemble the RAM Module from the RAM socket (#13)
- 14. Disconnect the FDD FPC from the M/B.
- 15. Disassemble the CDROM after removing the SCREW (#14)

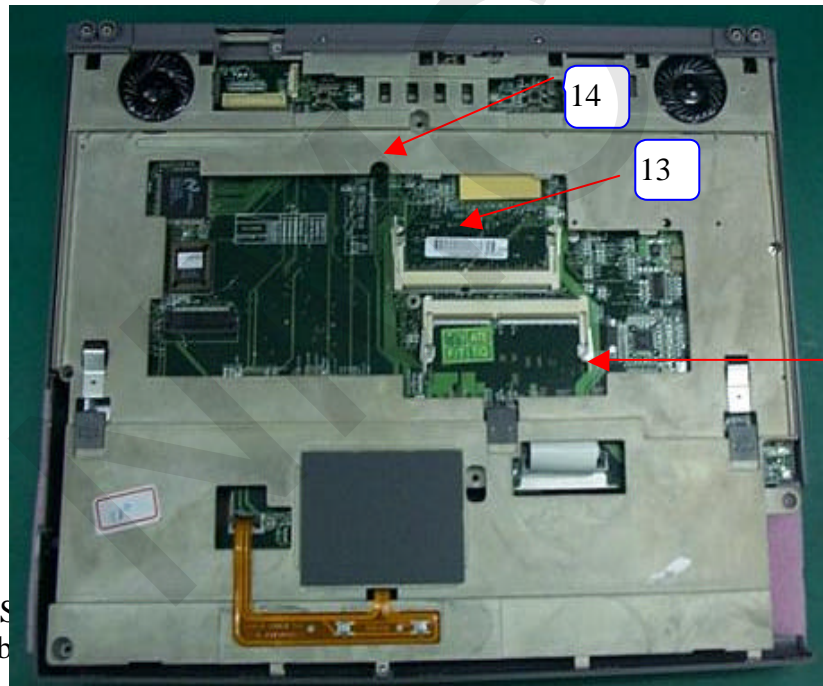

- 16. Unscrew S
- 17. Disassemb

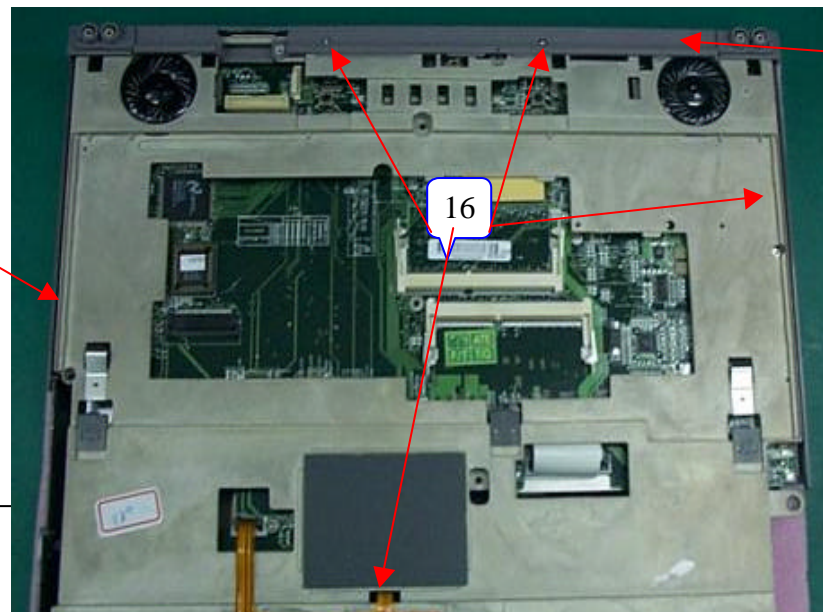

18. Disassemble the M/B assembly from the bottom cabinet.

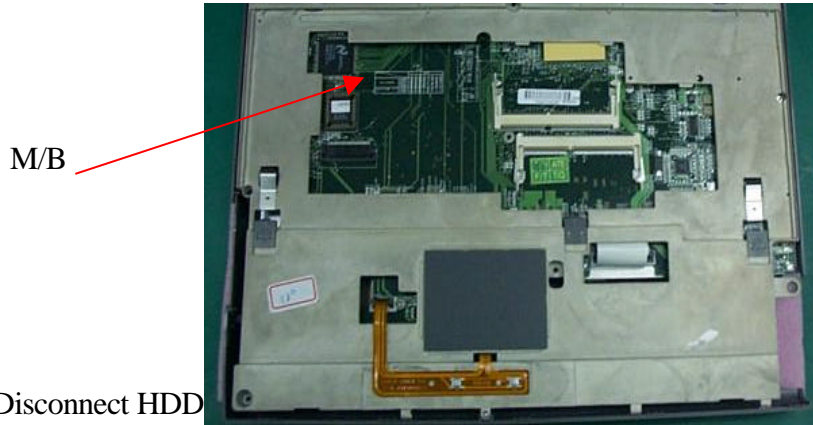

19. Disconnect HDD
20. Disconnect MODEM CABLE.

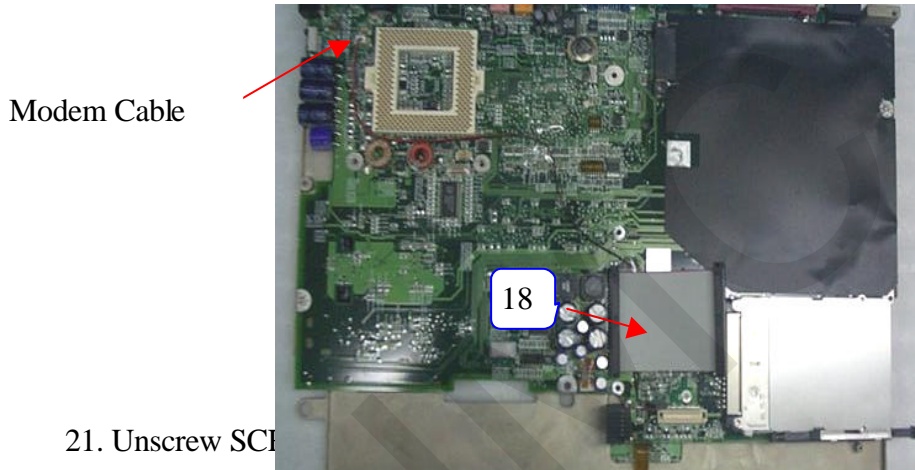

21. Unscrew SCI

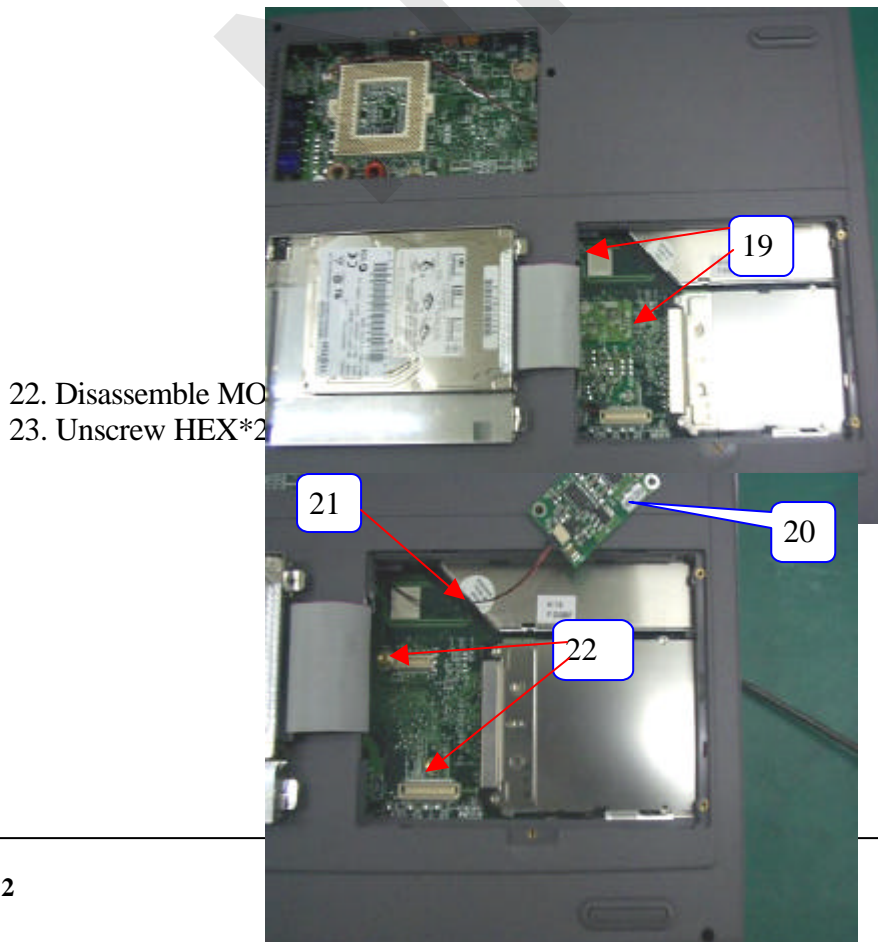

22. Disassemble MO
23. Unscrew HEX*2

24. Disconnect T/P FPC (#23) from the M/B.

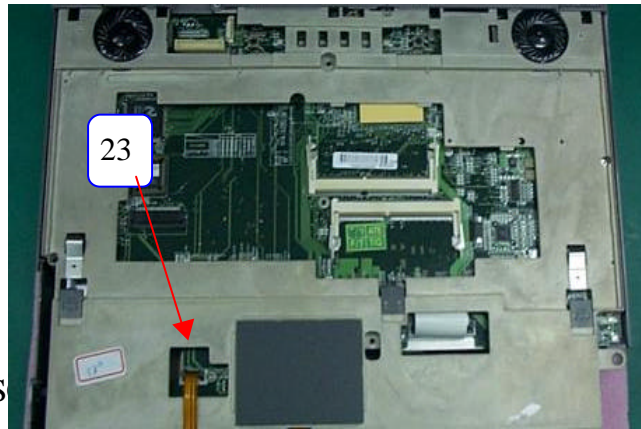

25. Unfasten the S

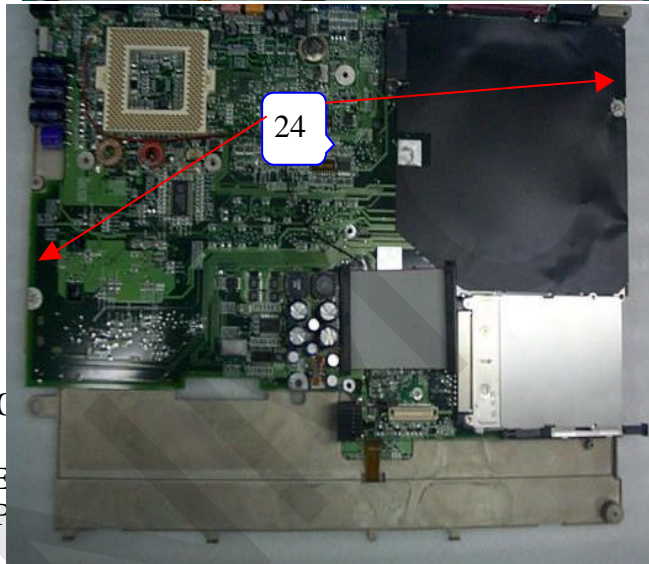

TOP HOUSING

- 1. Unscrew SCRE
- 2. Disassemble SP

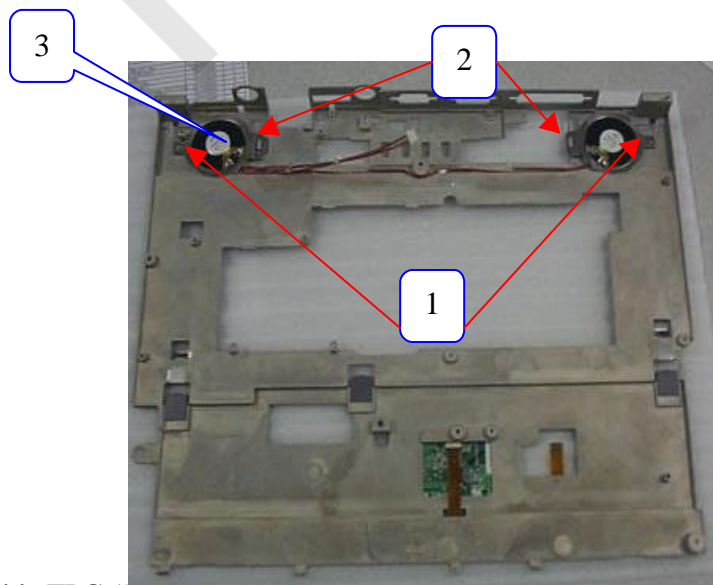

3. Disassemble FPC (#4) from the TOUCH PAD (#5).

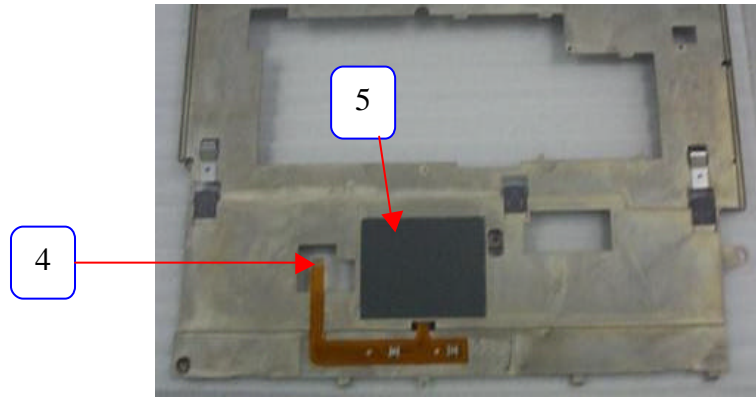

NMNC

4. Unscrew and disassemble SWITCH CABLE (#6).

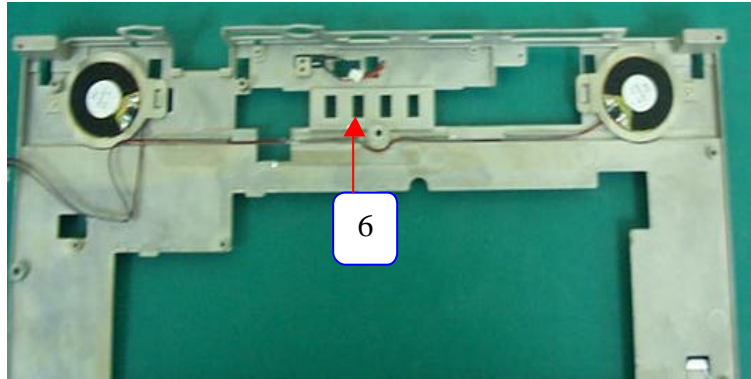

5. Disassemble K/B SPRING (#7)

6. Disassemble LATCH and SPRING (#8) from the TOP HOUSING (#9).

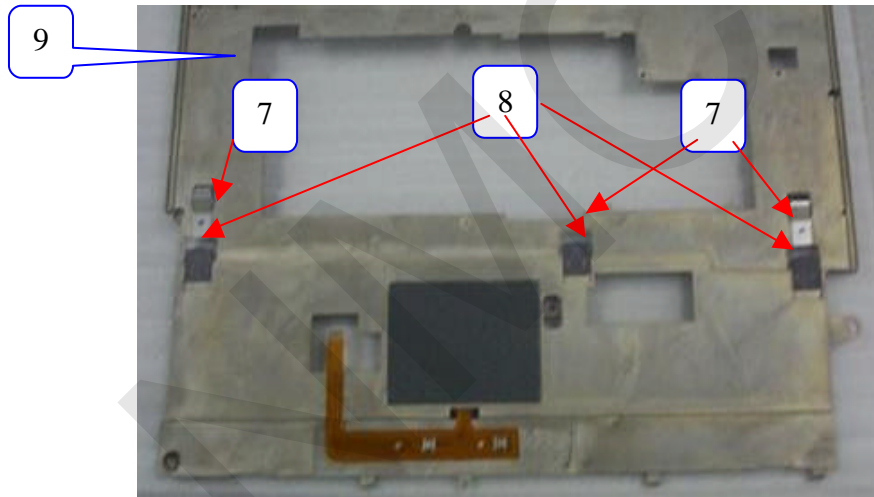

LCD PANEL DISASSEMBLY (14" CHIMEI)

1. Unfasten SCREWS*4 (#1, #2) of the FRONT CABINET (#3).
2. Disassemble FRONT CABINET.



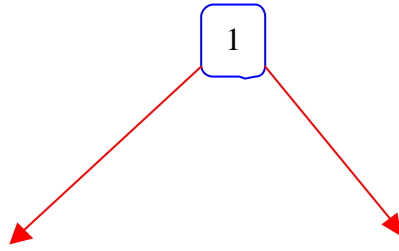

3. Unscrew SCREWS*4 (#4) from the BACK CABINET.

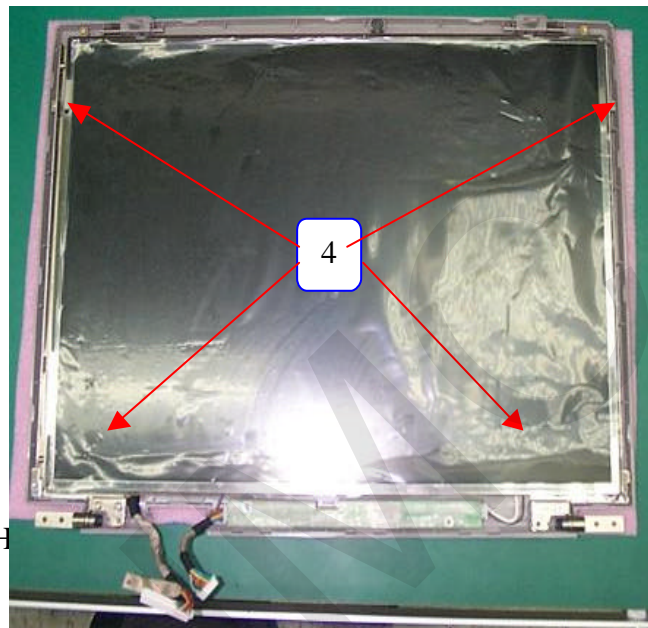

4. Remove SH

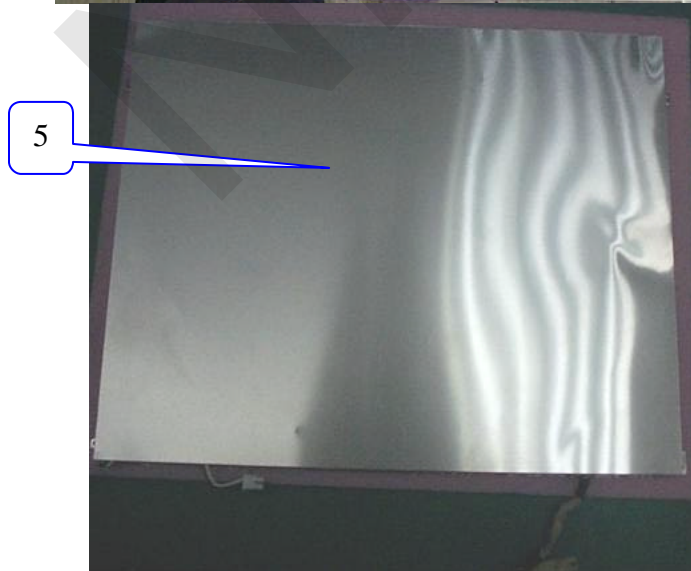

5. Disconnect LCD CABLE (#6) from the LCD (#7)

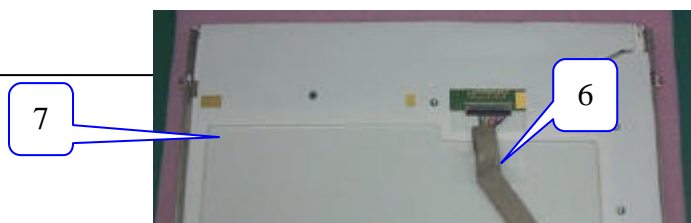

- 6. Unscrew SCREW*2 (#8) and disassemble BRACKET_R(#9)
- 7. Unscrew SCREW*2 (#10) and disassemble BRACKET_L (#11).



- 8. Unfasten SCREWS (#12) from the HINGE.
- 9. Disassemble HINGE_L (#13) and HINGE_R(#14).
- 10. Disassemble HINGE BRACKET_L (#15) and HINGE BRACKET_R (#16).

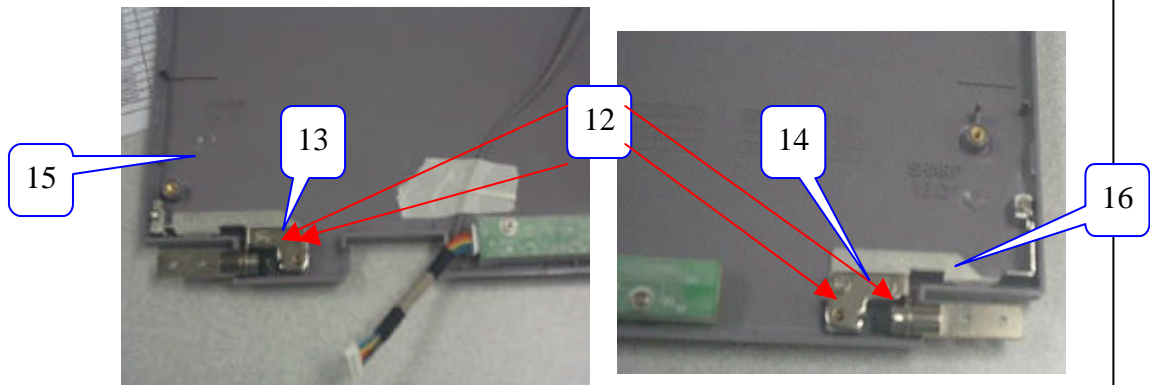

- 11. Disconnect INVERTER CABLE (#17) from the INVERTER (#18).

- 12. Unfasten SCREWS*2 (#19) of the INVERTER.
- 13. Remove INVERTER MYLAR (#20)

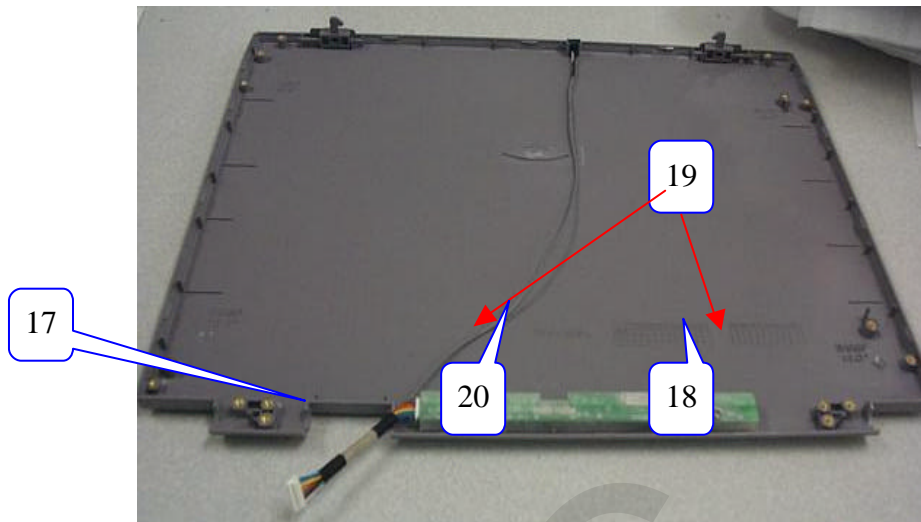

- 14. Disassemble MIC (INVERTER CABLE) (#21).
- 15. Disassemble KNOB (#22).
- 16. Disassemble HOOK_L(#23) and HOOK_R(#24) and SPRING from the BACK CABINET (#25).

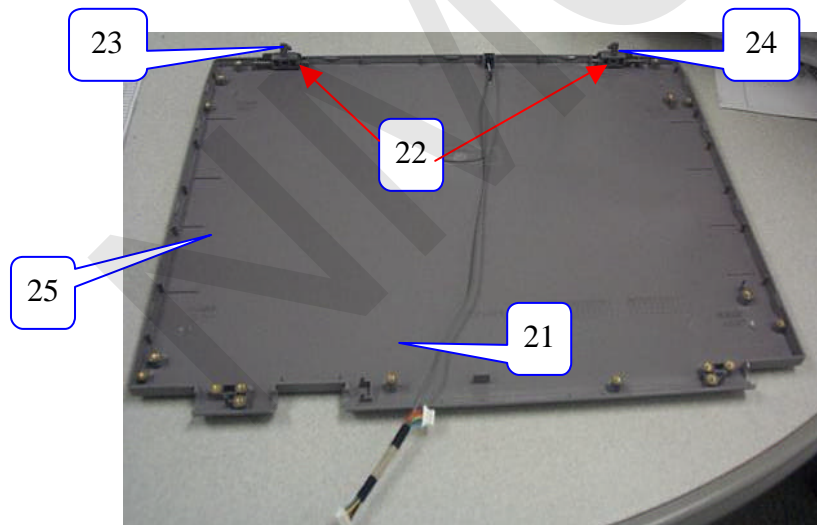

Notebook PC Service Manual

Model: 340S2

Chapter 5

Trouble Shooting

UNIWILL COMPUTER CORP.

No. 24 Pei Yuan Road
Chung Li Industrial Park, Chung Li City
Tao Yuan Hsien, Taiwan
R.O.C.
TEL: 886-3-461-6000
FAX: 886-3-461-6317
URL: [http:// www.uniwill.com.tw/](http://www.uniwill.com.tw/)

Trouble Shooting List

- 5.1 No display**
- 5.2 VGA controller failure**
- 5.3 LCD no display / Invalid picture**
- 5.4 External monitor has no display or color incorrect**
- 5.5 Memory test error**
- 5.6 Keyboard test error**
- 5.7 Touch pad test error**
- 5.8 Diskette drive test error**
- 5.9 Hard disk drive test error**
- 5.10 CMOS test error**
- 5.11 SIO port test error**
- 5.12 PIO port test error**
- 5.13 Audio failure**
- 5.14 No power symptom**
- 5.15 CDROM drive test error**
- 5.16 Stopping in LCD screen while booting**
- 5.17 PCMCIA Card Bus failure**
- 5.18 IR Port cannot transfer data**
- 5.19 Modem Failure**

5.1 No display (system failure)

Symptom: There is no display on both LCD and Monitor after power on although the LCD and Monitor are known-good.

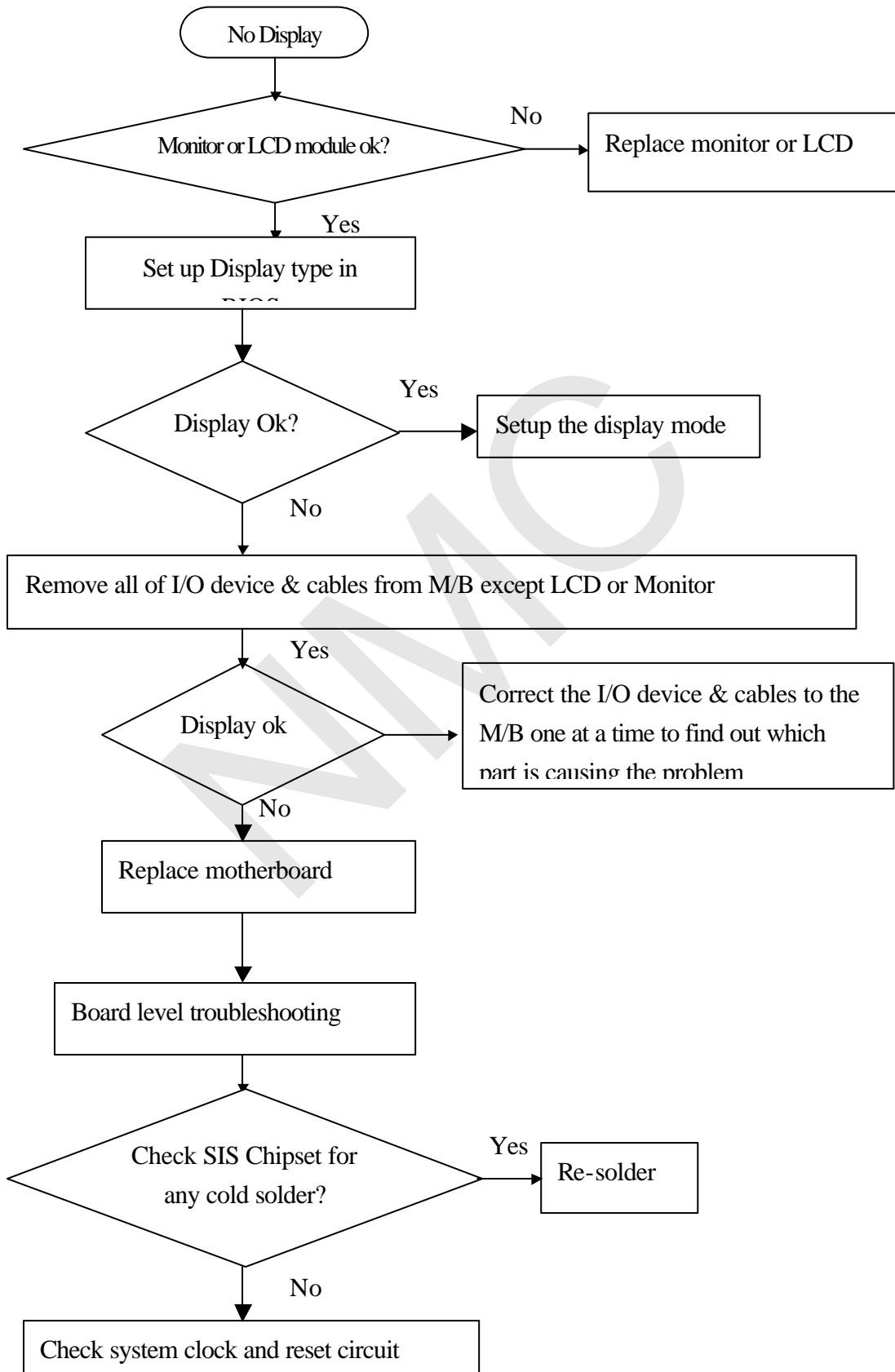

5.2 VGA controller failure

Symptom: There is no display on both LCD and Monitor although Power-On-Self-Test is passed

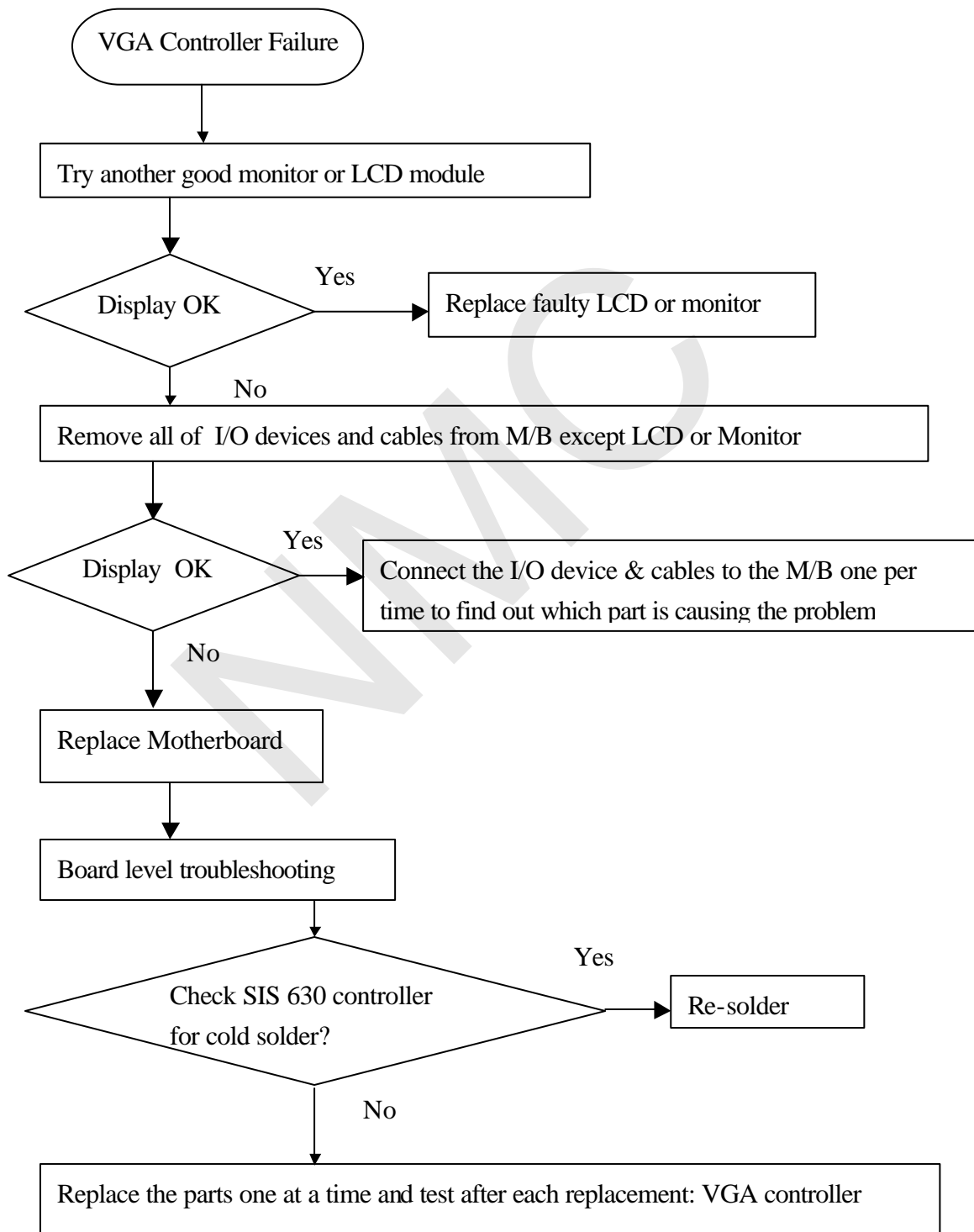

5.3 LCD no display or Invalid Picture

Symptom: The LCD shows nothing or abnormal picture, but it is ok for external monitor.

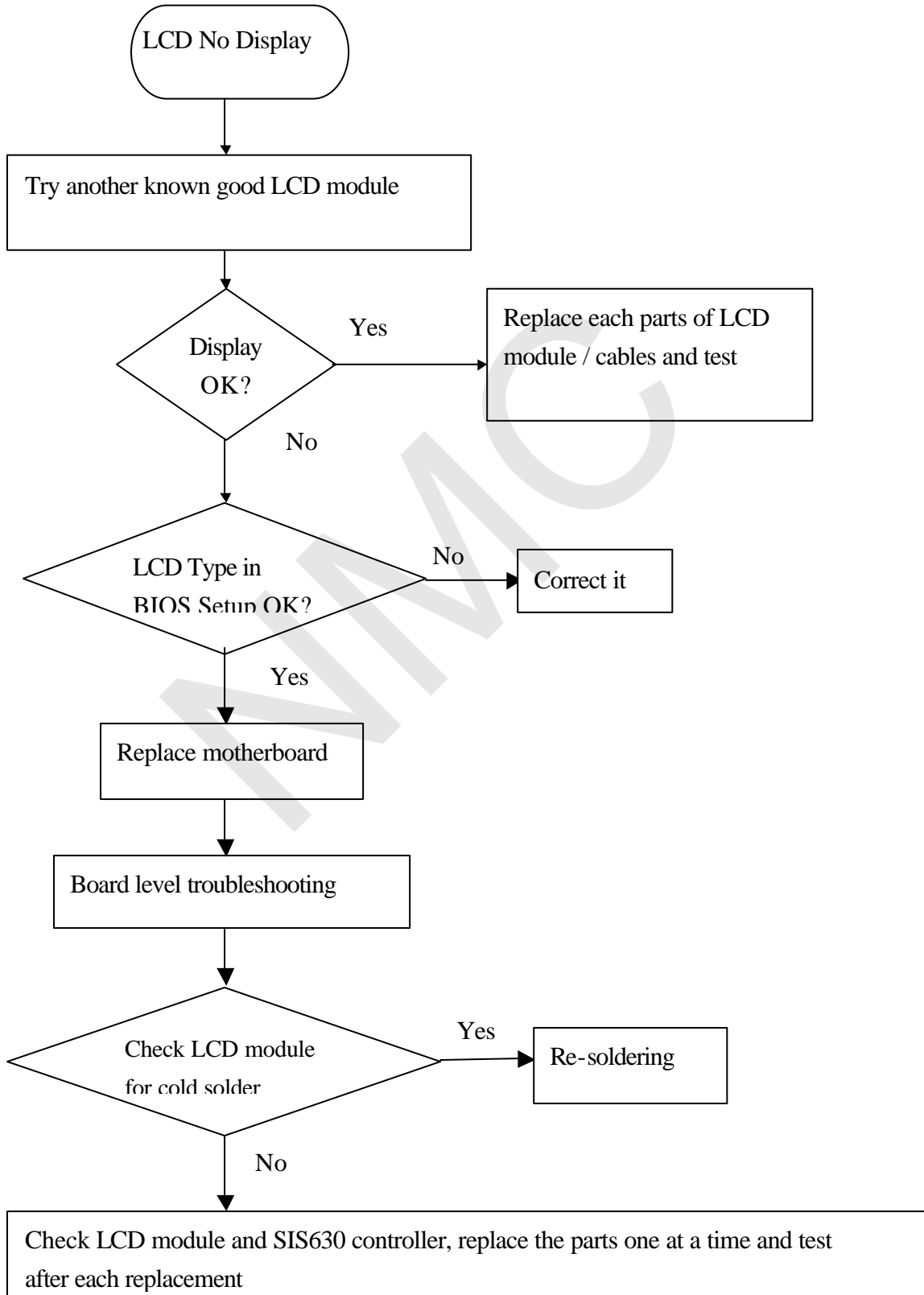

5.4 External monitor has no display or color abnormal

Symptom: The CRT monitor shows nothing or abnormal color, but it is ok for LCD

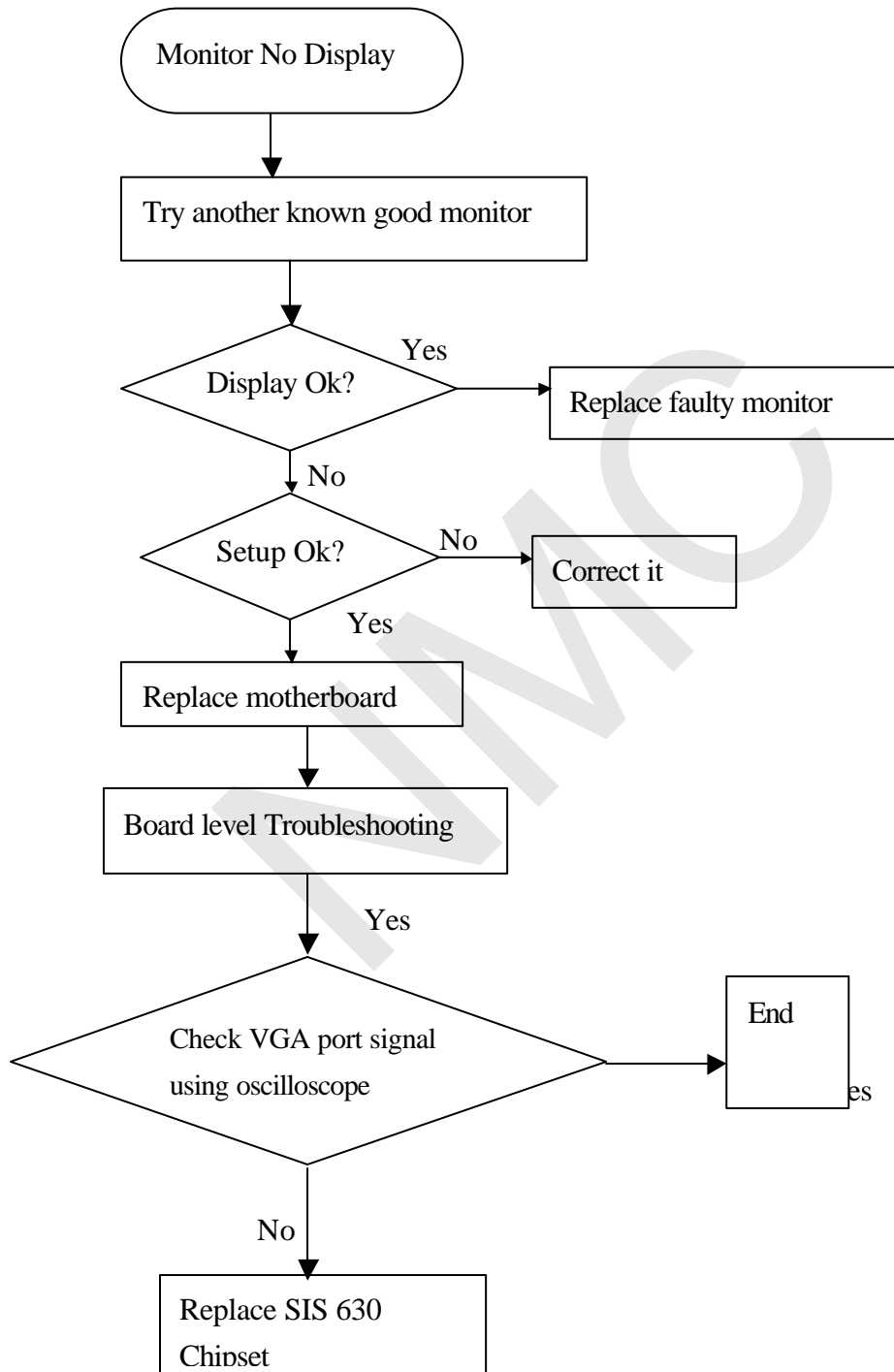

5.5 Memory test error

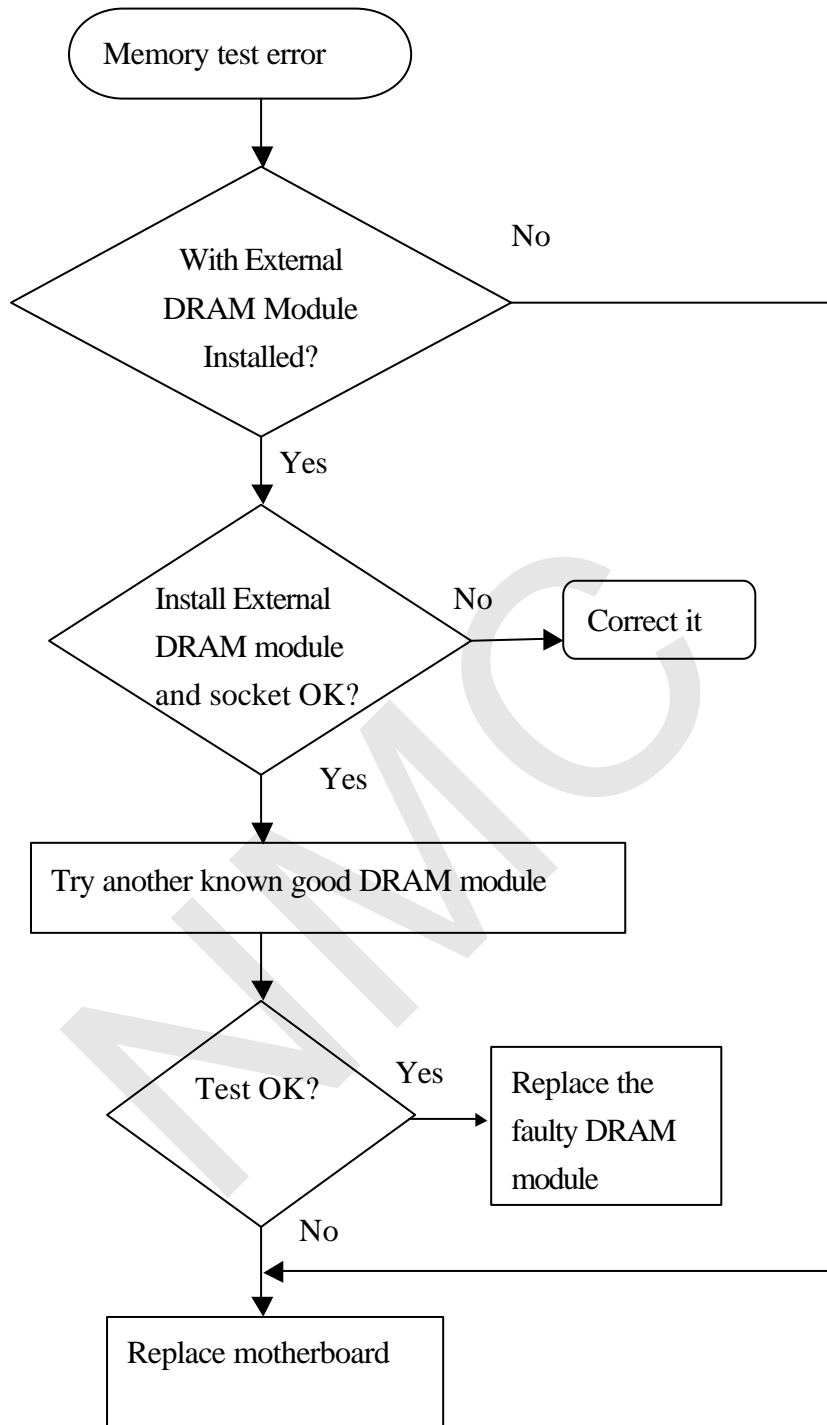

5.6 Keyboard test error (including external K/B & PS/2 mouse)

Symptom: error message of keyboard failure is shown or any key doesn't work

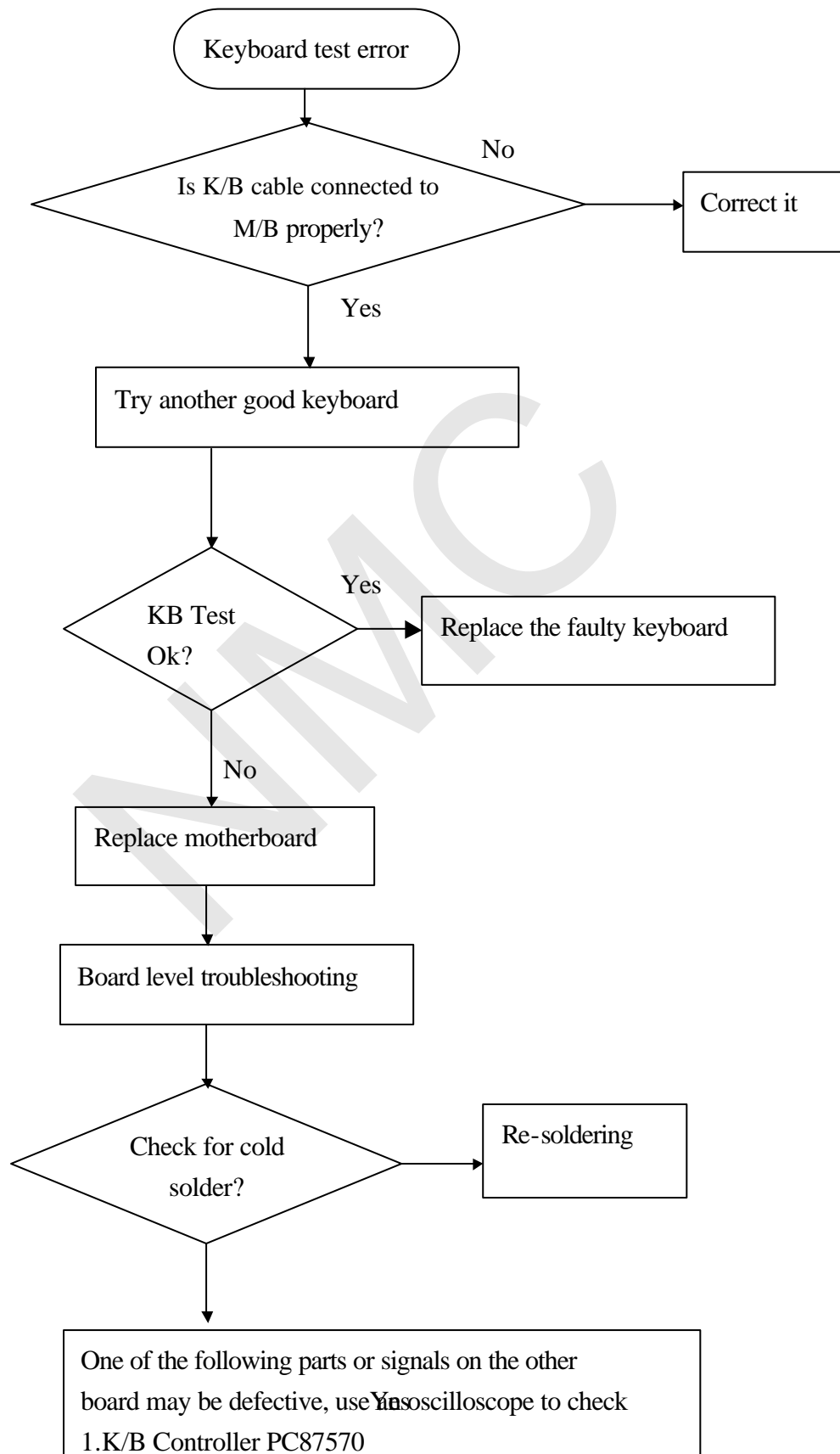

5.7 Touch Pad test error

Symptom: An error message is shown when the Touch Pad point is enabled

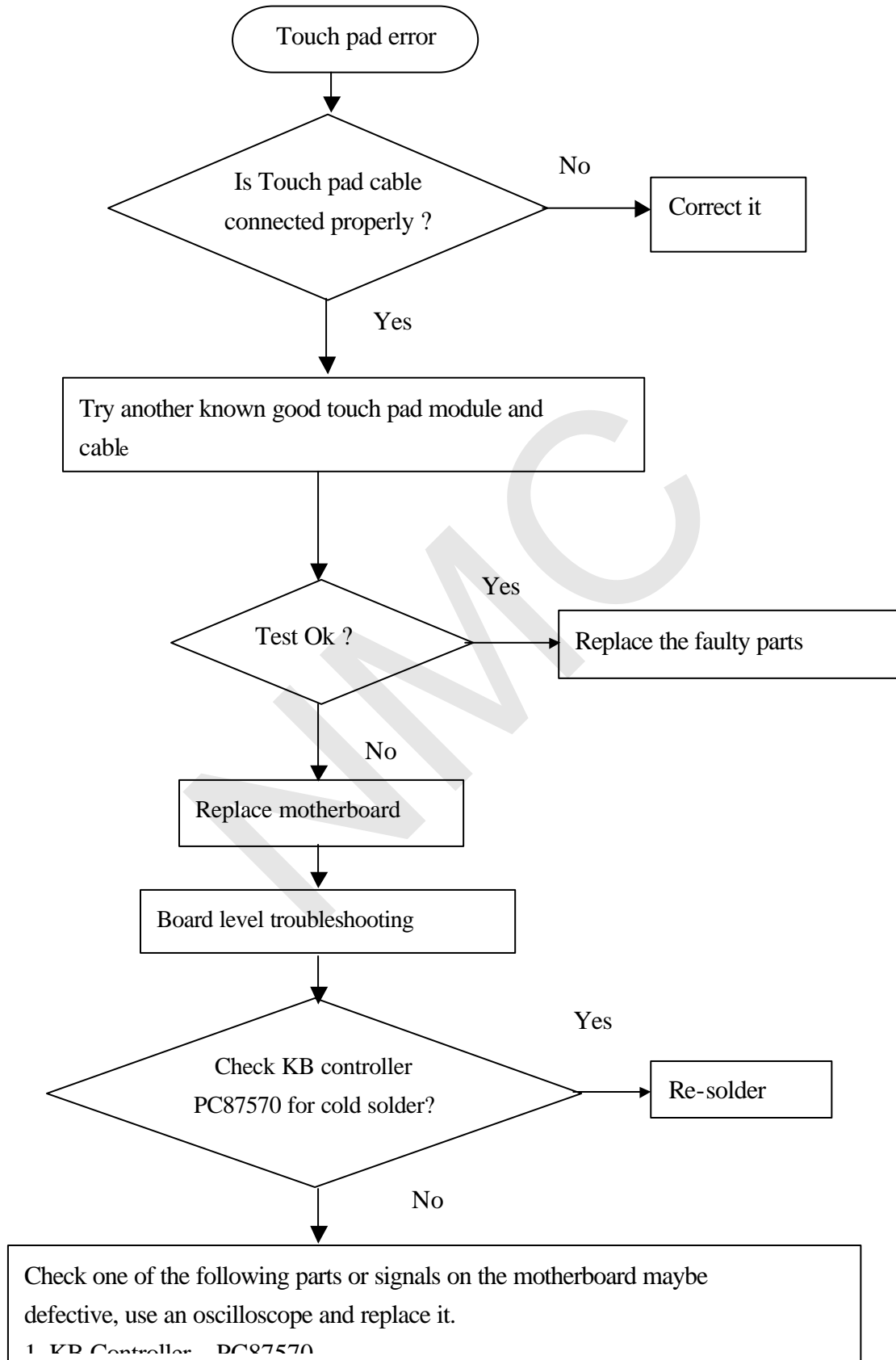

5.8 Diskette drive test error

Symptom: An error message is shown while loading data from FDD to system

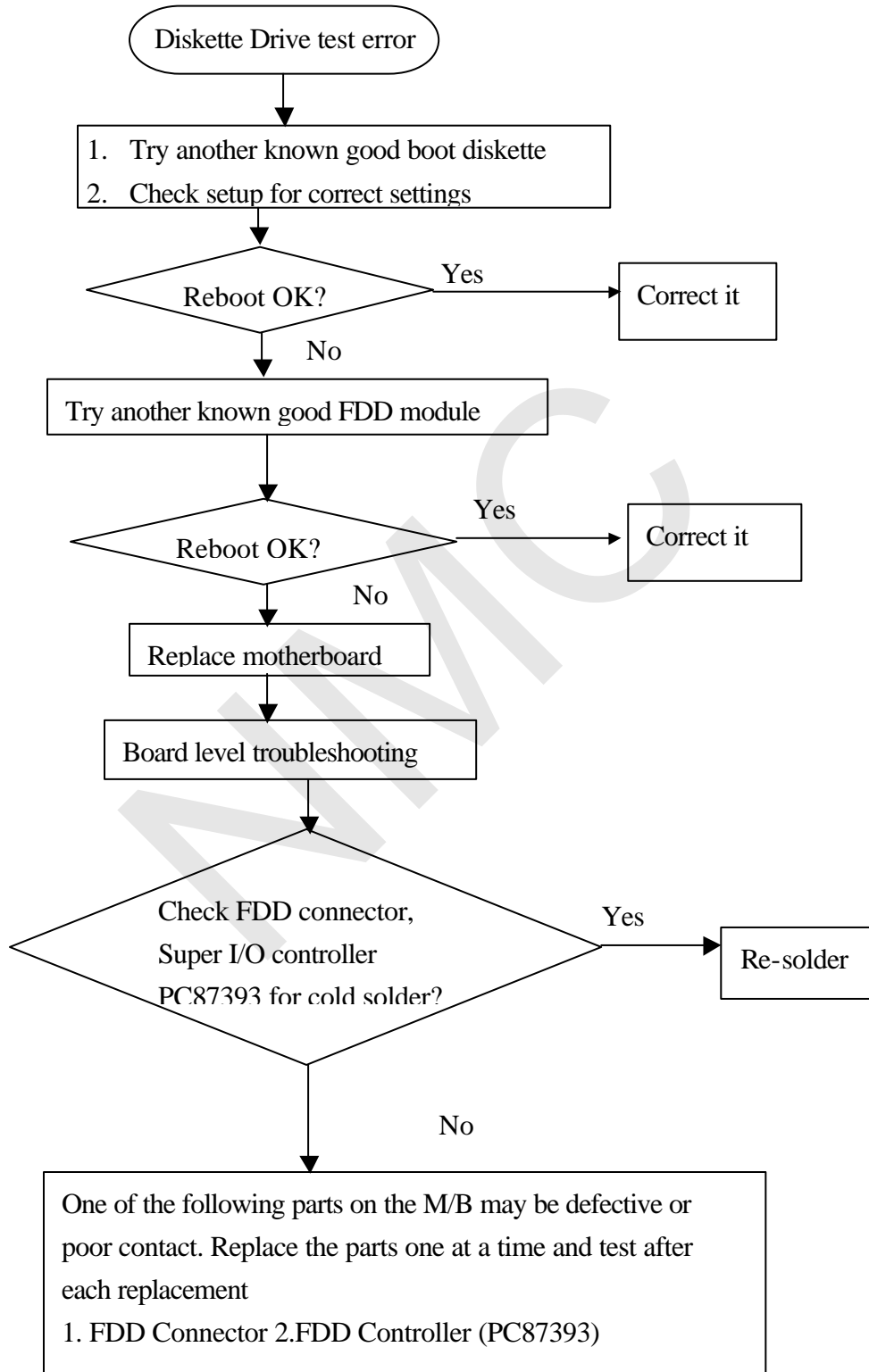

5.9 Hard disk drive test error

Symptom: Either an error message is shown, or the drive motor spins non-stop, while reading data from or writing data to Hard disk

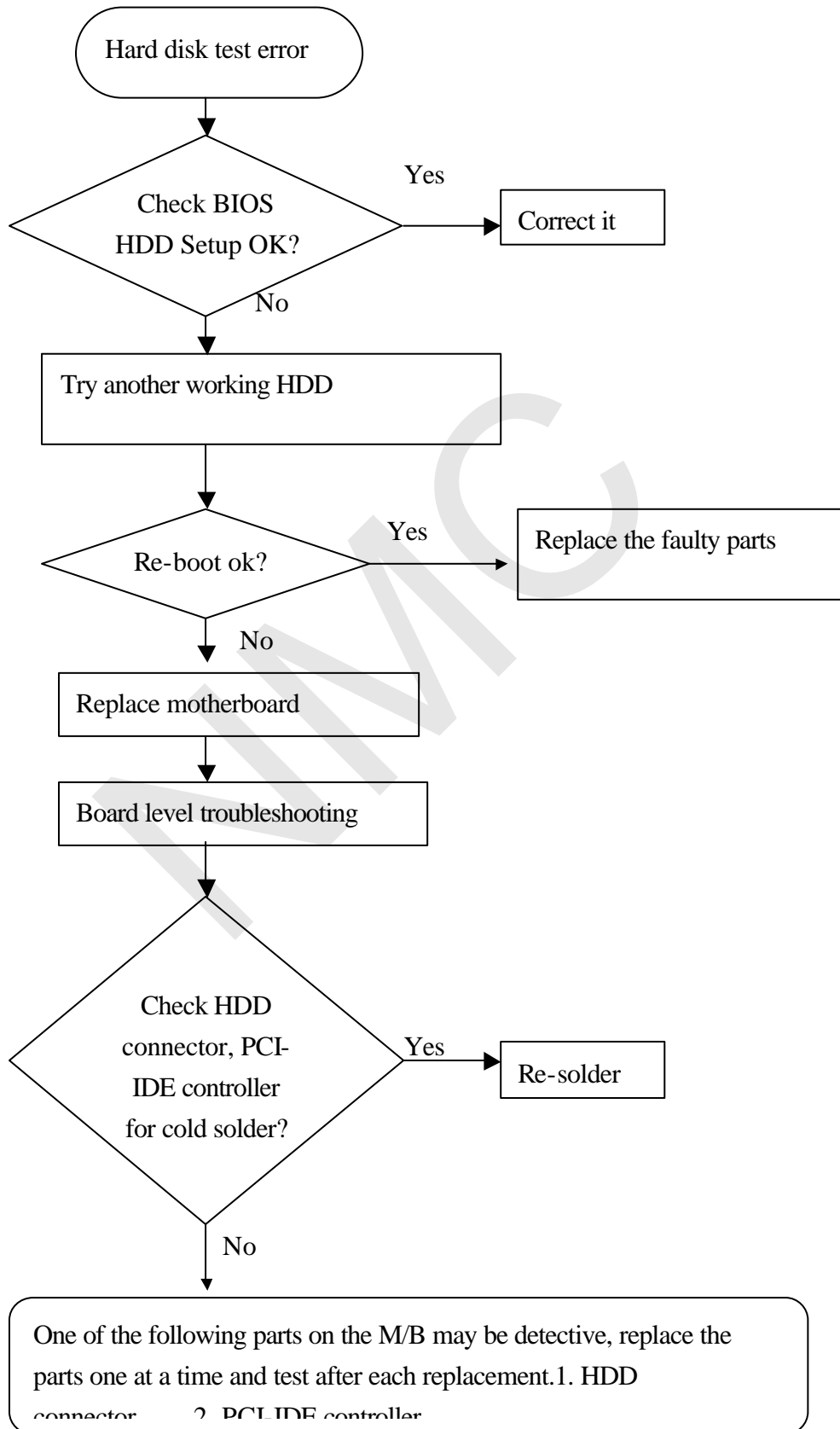

5.10 CMOS test error

1. CMOS data lost, or inaccurate system time & data

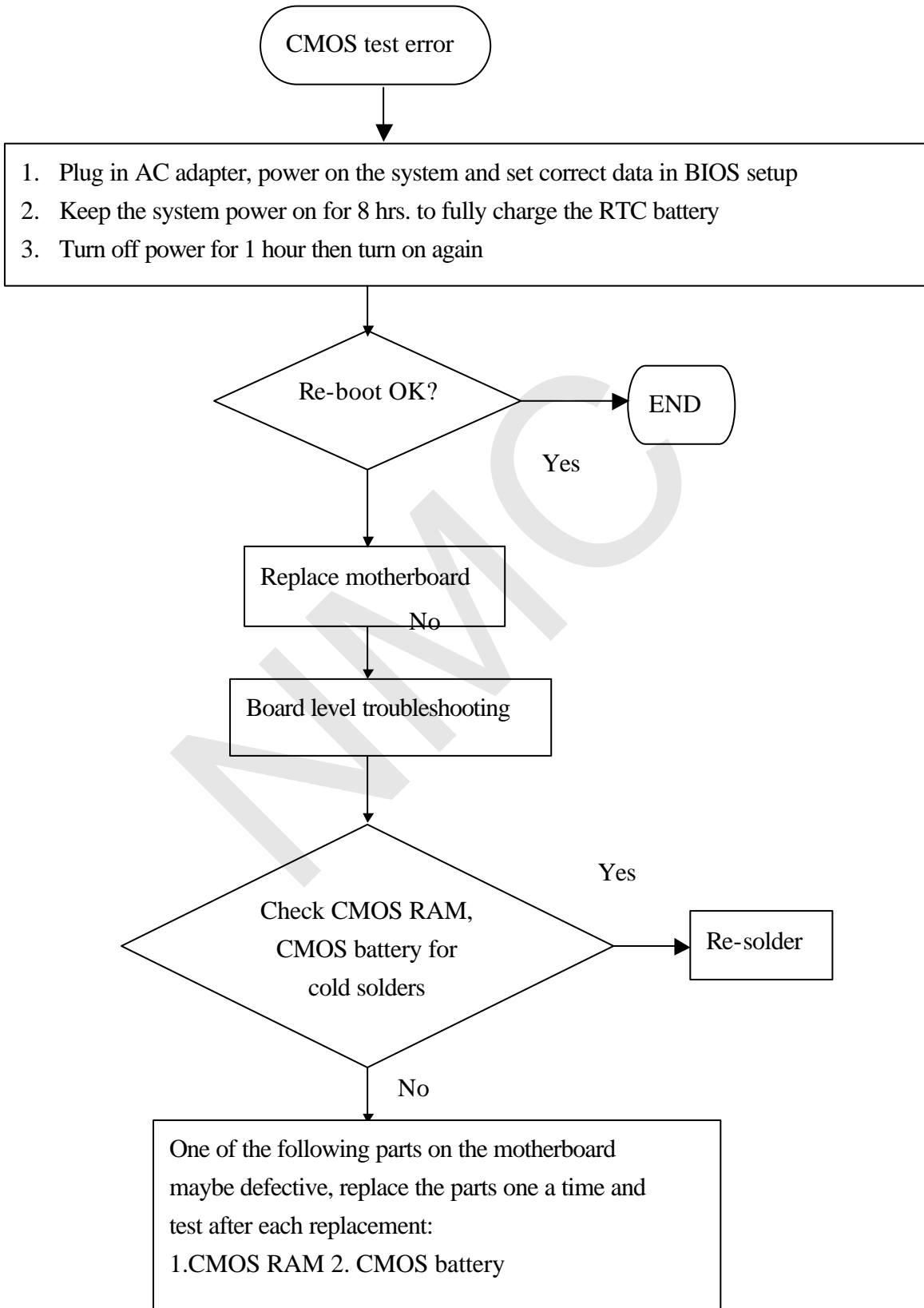

5.11 SIO port test error

Symptom: An error display occurs when a mouse or other I/O device is installed

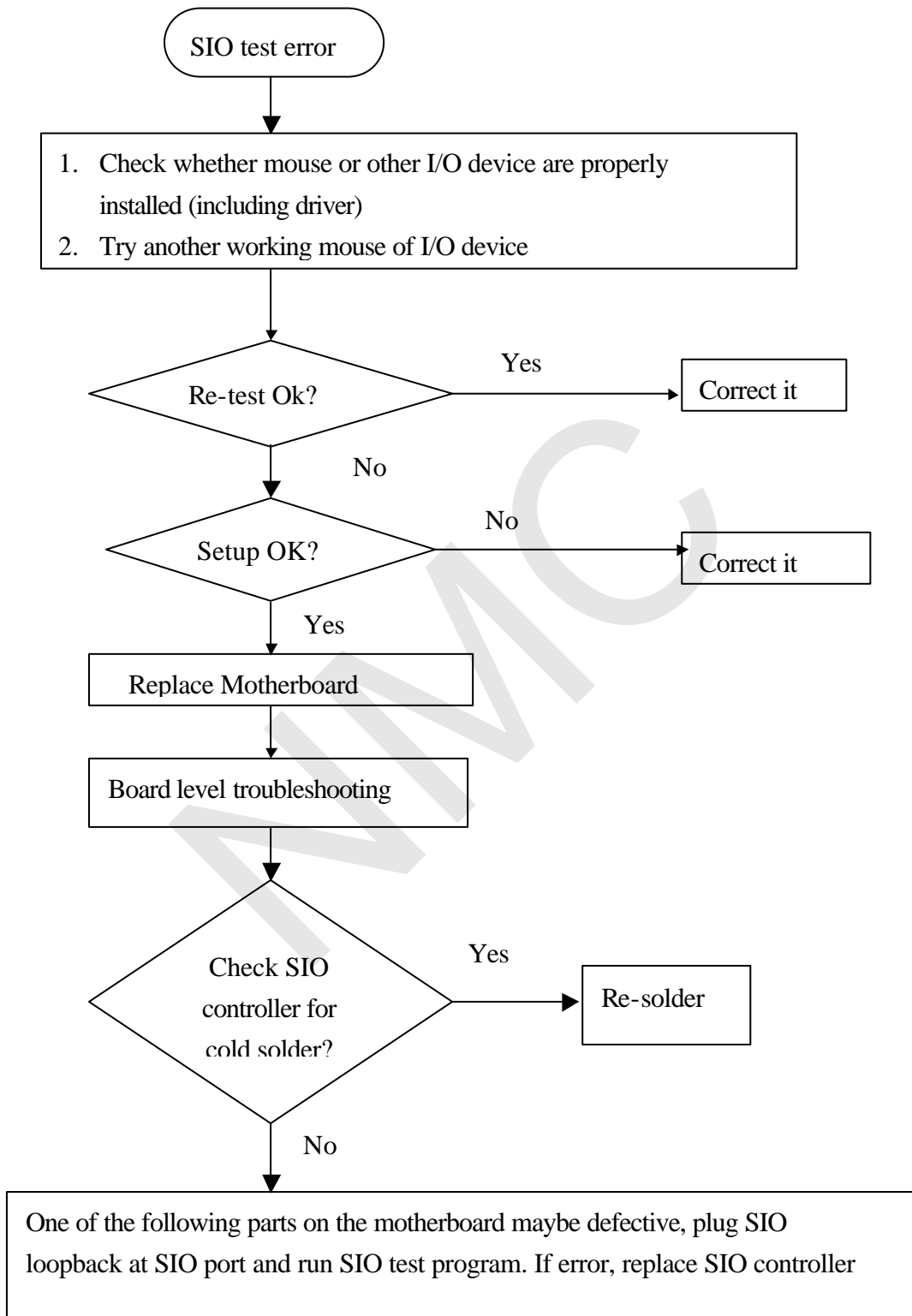

5.12 PIO port test error

Symptom: When a print command is issued, printer prints nothing or garbage.

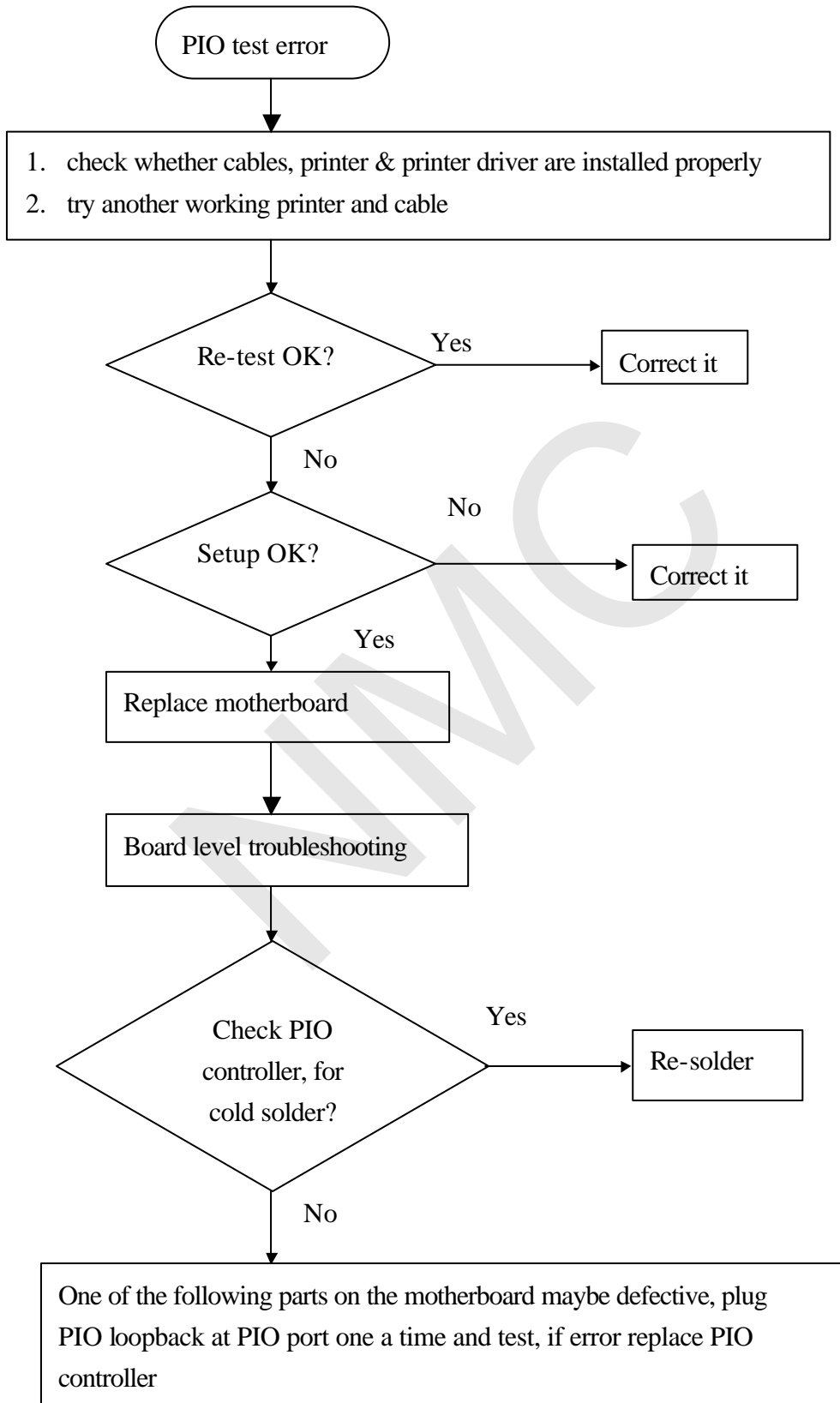

5.13 Audio failure

Symptom: No sound from speaker after audio drive is installed.

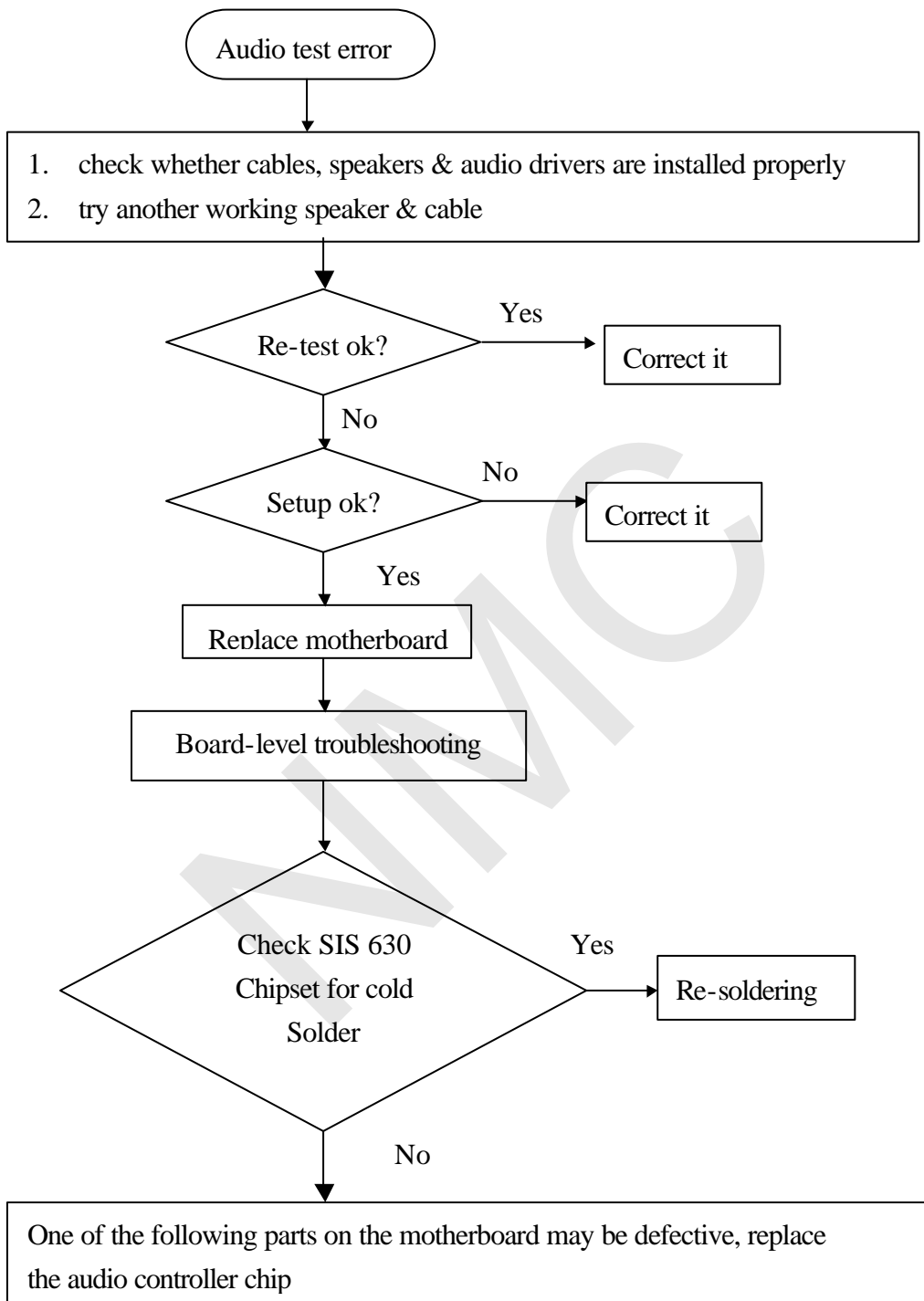

5.14 No power symptom:

Symptom: When the power button is pressed, nothing happens, power indicator is not light up.

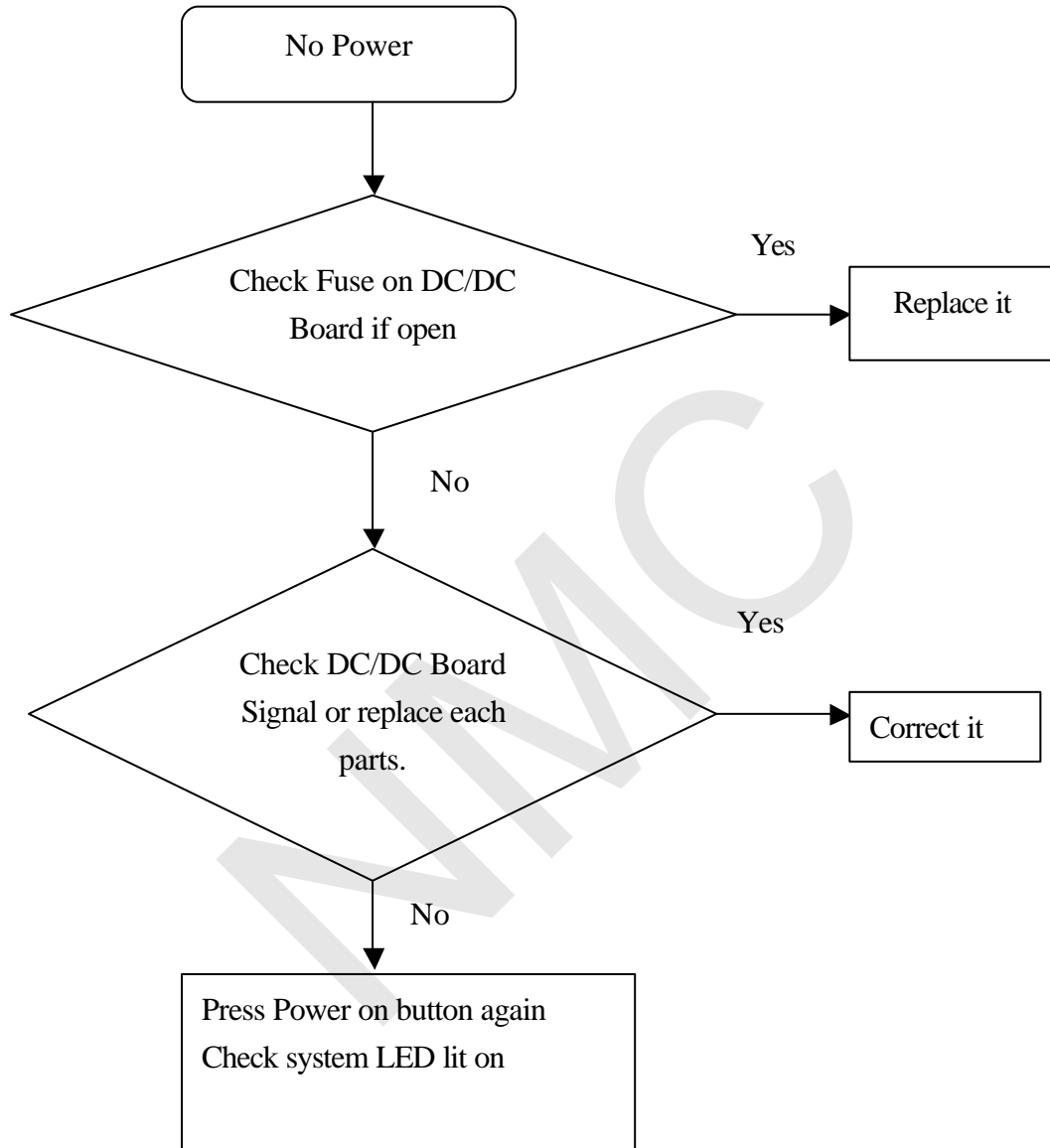

5.15 CD-ROM drive test error

An error message is shown when reading data from CD-ROM drive

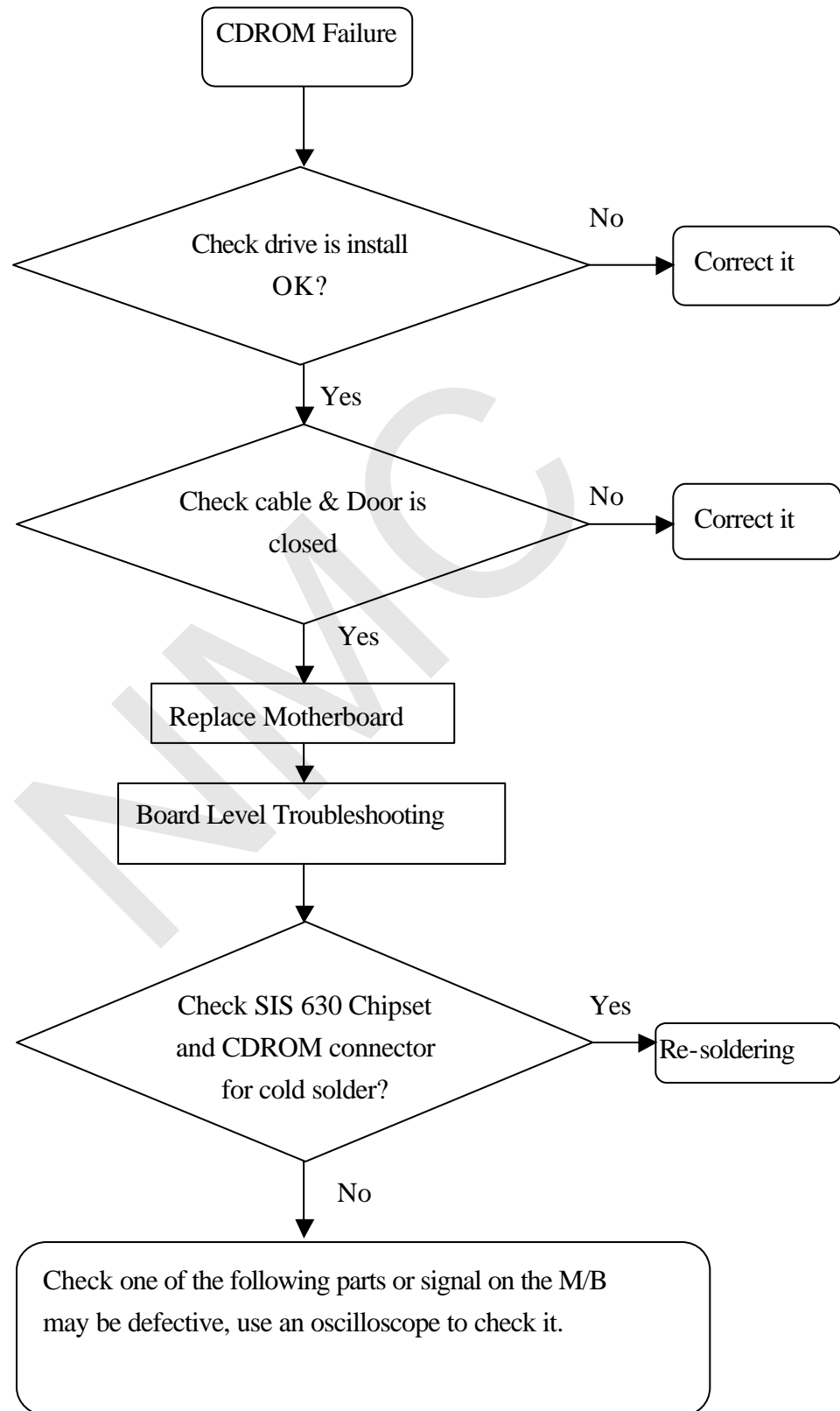

5.16 Stopping in LCD screen while booting

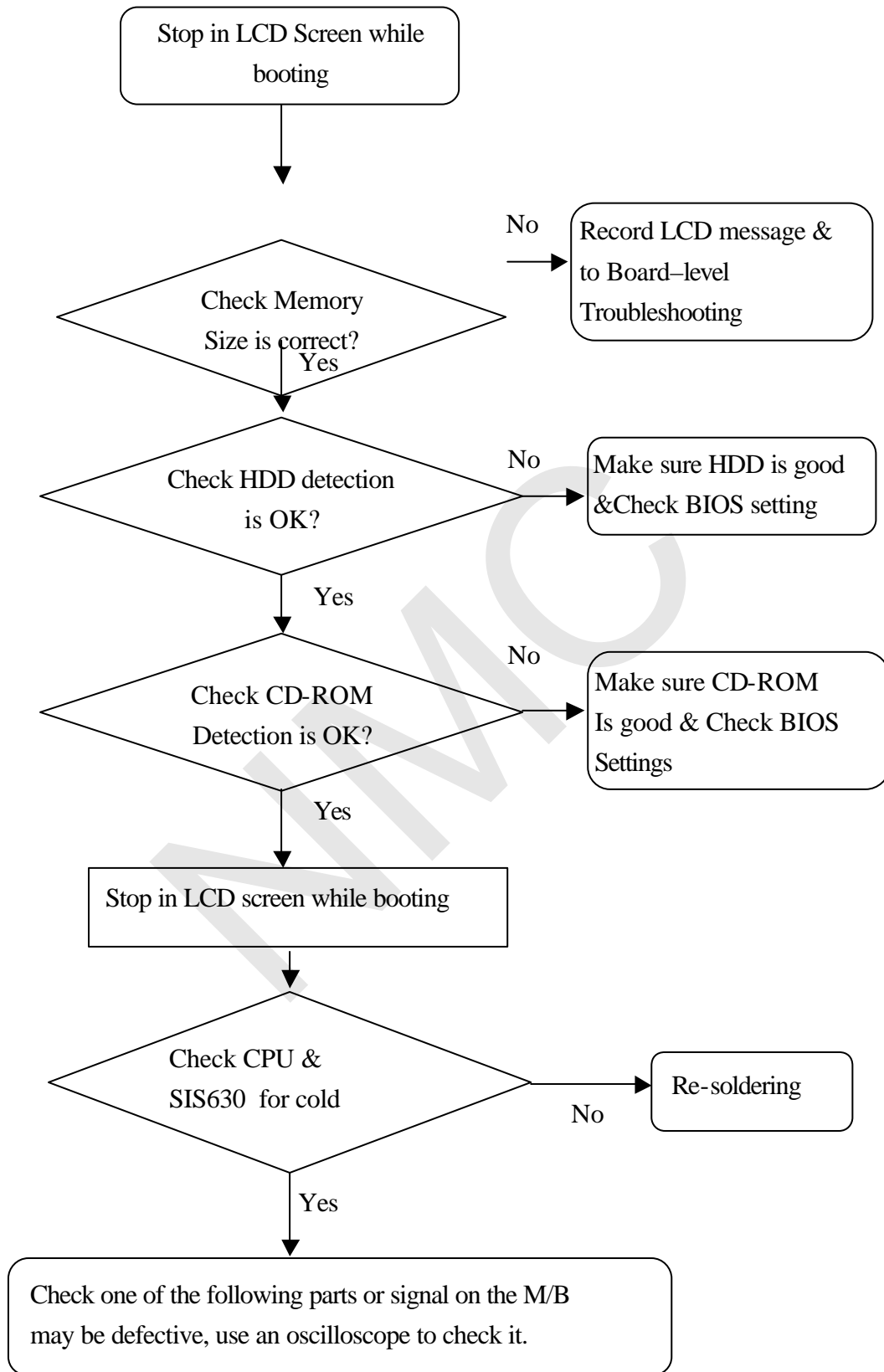

5.17 PCMCIA CardBus failure

Symptom : when insert PCMCIA card to PCMCIA slot, but system can't detect.

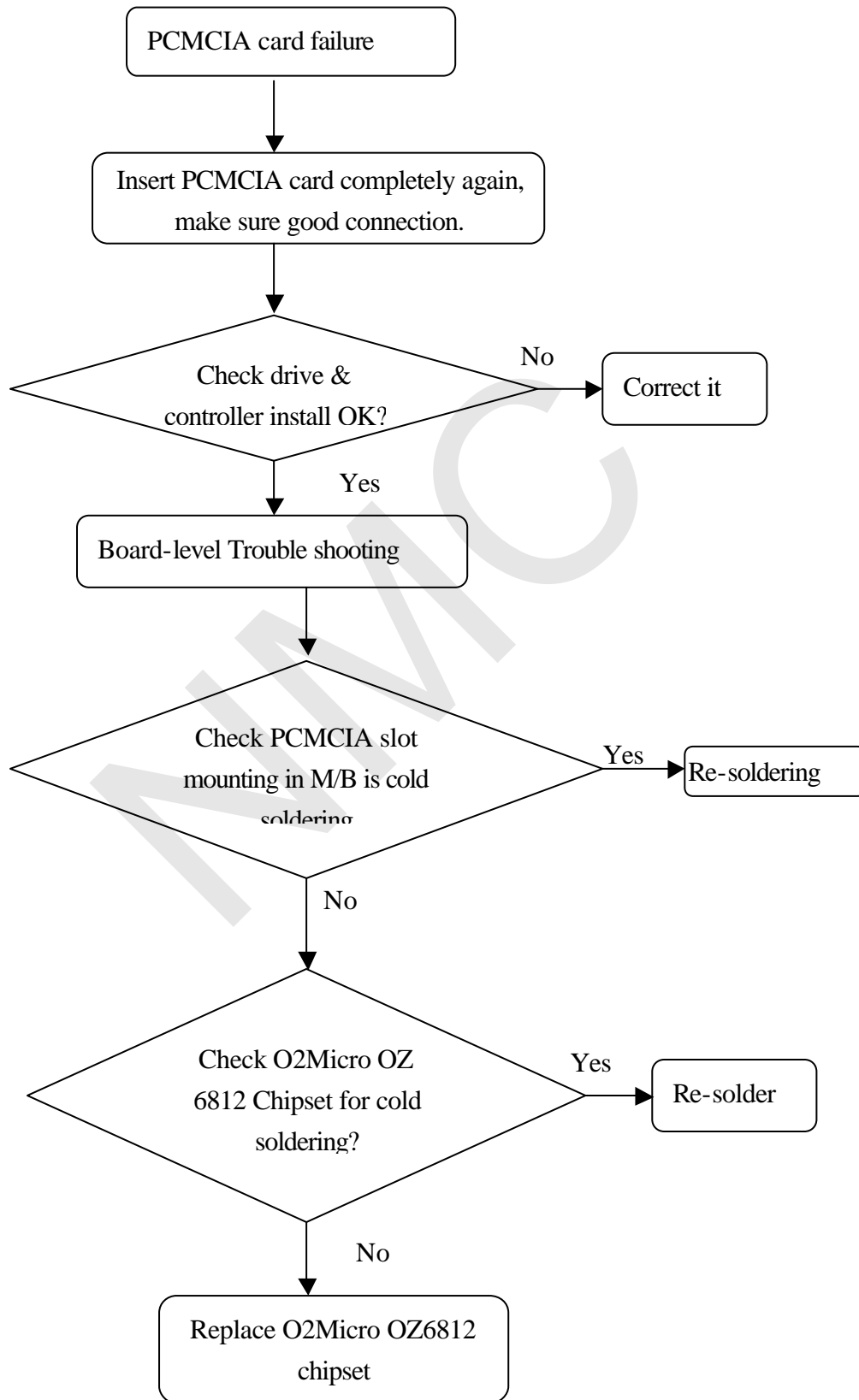

5.18 IR Port can't transfer data.

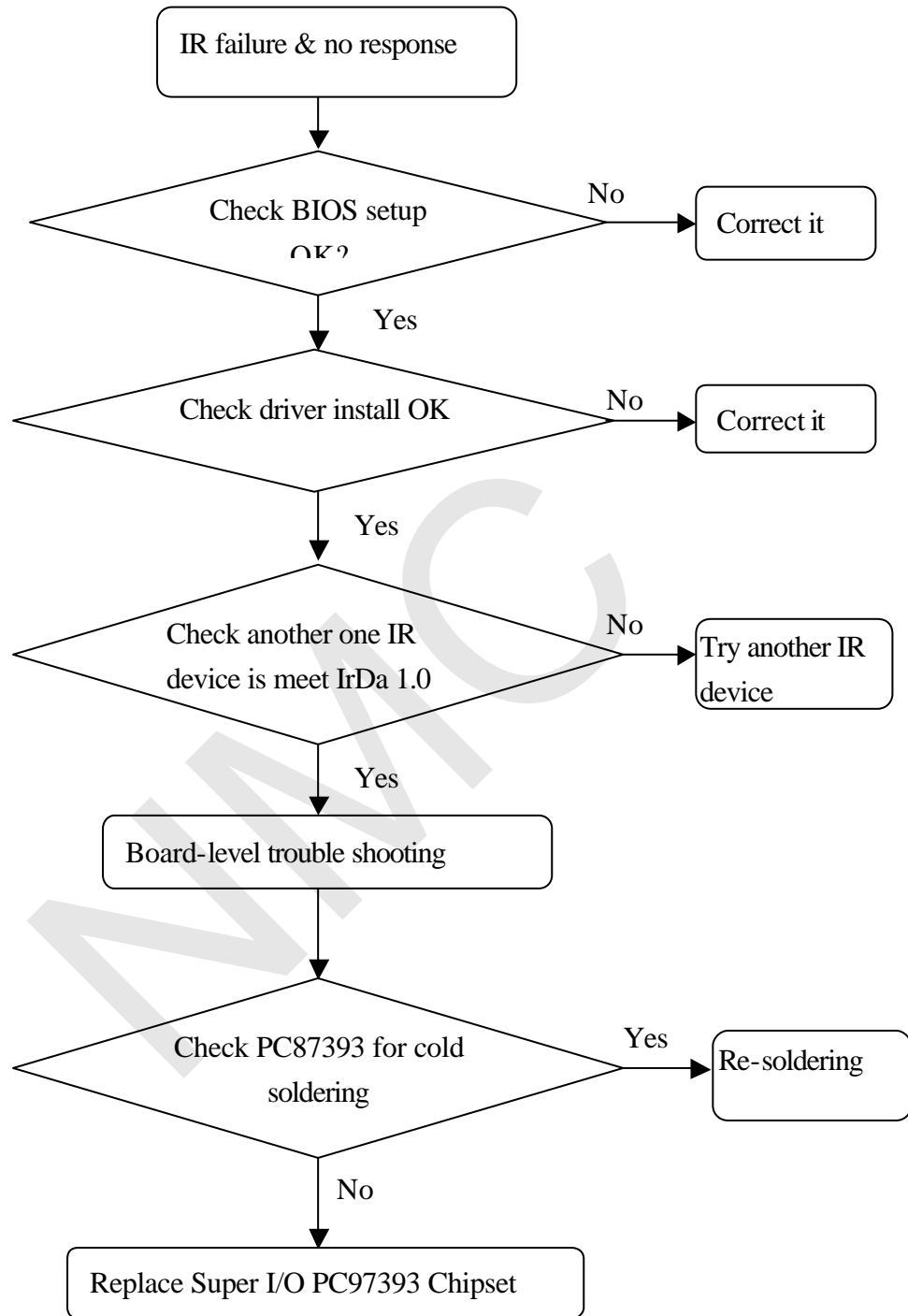

5.19 Modem failure

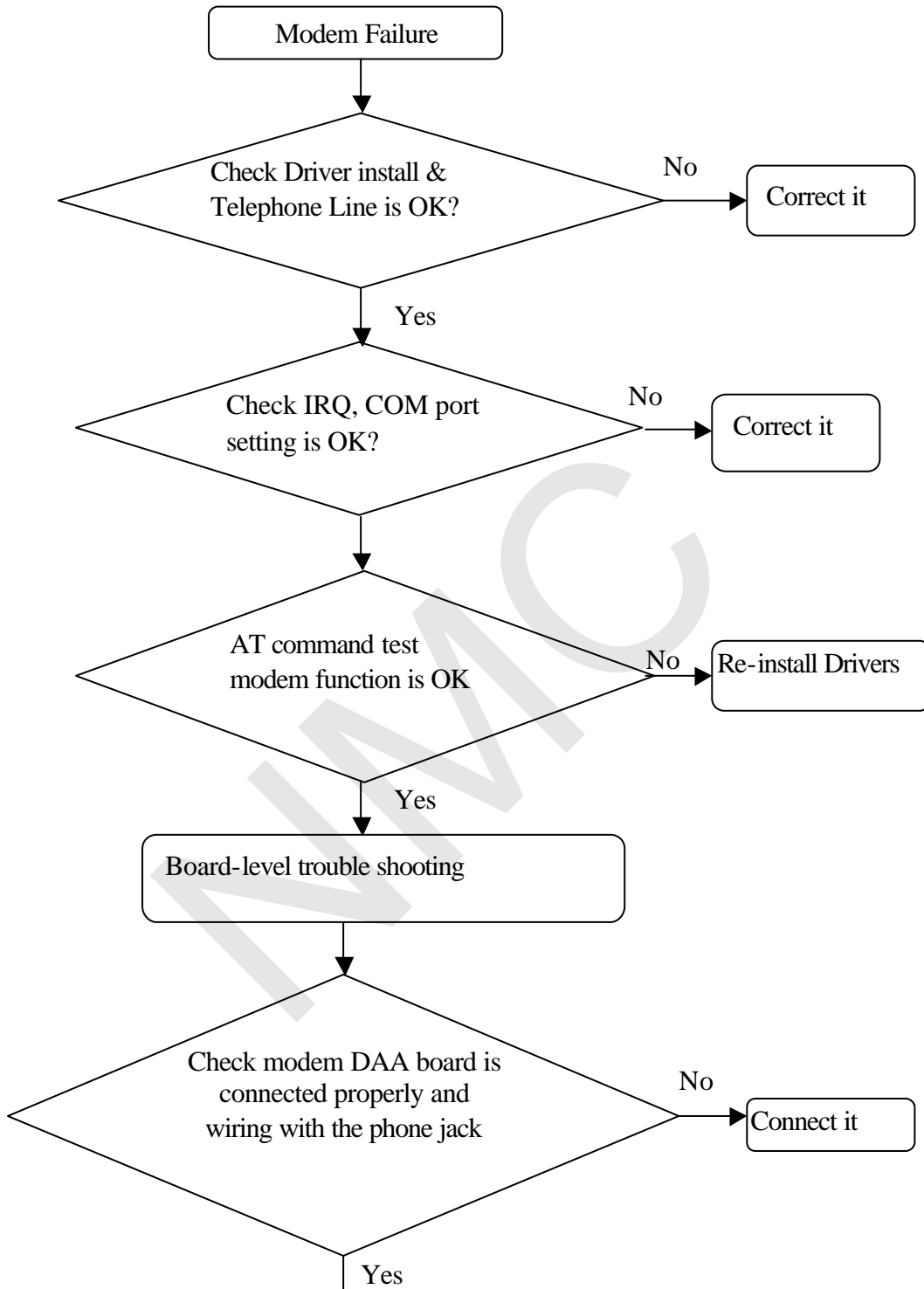

Notebook PC Service Manual

Model: 340S2

Chapter 6 **Peripheral Devices**

UNIWILL COMPUTER CORP.

No. 24 Pei Yuan Road
Chung Li Industrial Park, Chung Li City
Tao Yuan Hsien, Taiwan
R.O.C.
TEL: 886-3-461-6000
FAX: 886-3-461-6317
URL: [http:// www.uniwill.com.tw/](http://www.uniwill.com.tw/)

6.1 LCD

- I. 14.1" TFT, XGA - Vendor – HYUNDAI, CHI MEI, CPY
- II. 12.1" DSTN, SVGA – Vendor – SHARP
- III. 13.3" TFT, XGA – Vendor – ACER, IMES
- IV. 12.1" TFT SVGA – Vendor - Sanyo

6.2 FDD

External / Swappable FDD: 3.5" format
 Capacity : 720KB / 1.44MB / 1.2MB (3 mode)

6.3 HDD

Dimension : 2.5", 8.5 / 9.5 mm height
 Vendor : Toshiba and Fujitsu

6.4 CD-ROM

Vendor : QMATE, TEAC
 Dimension : 12.7-mm height, 12/8 cm CD-ROM disc
 PIO Mode 4, 24X
 Average 3.1W, Sleep 0.05W
 ATAPI Interface

DVD

Vendor : TORISAN, TOSHIBA
 Dimension : 12.7mm height, 12/8cm CD-ROM disc
 PIO Mode 4
 Average 3.1W, Sleep 0.05W
 ATAPI Interface

6.5 BATTERY:

Li-ION

Vendor : PANASONIC , GS
 Battery type : Li-Ion, 8 cells (4S2P)
 Battery capacity : 14.8V, 3200mAH, (47.36Whrs)

- 1.1.2. **Charge Voltage** : 16.8V +2.5% -1.0%
- Charge temperature : 0~45°C
- Discharge temperature : -20~60°C
- End of Discharge : 11V
- Cycle life= 500 times
- Overcharge protection : when battery voltage reach 17.2 ±0.2V
- Over-discharge protection : when battery voltage decrease to 10 ± 1V
- Pre-charge current: 0.2A
- Charge current : When system is power off : 2A
 When system is powered ON : 1A

Ni-MH

Vendor : PANASONIC, TOSHIBA
 Battery Type : Ni-MH, 10 cells (10S)
 Battery Capacity : 12.0V, 4500mAh (54.0 watts)
 Charge voltage : 16.8V +2.5% -1.0%
 Charge temperature : 0~45°C

Discharge temperature : -20~60°C
 End of Discharge : 10V
 Cycle life= 500 times
 Pre-charge current: 0.2A
 Charge current : When system is power off : 2A
 When system is powered ON : 1A

6.6 TOUCH PAD

Synaptic
 Capacitor sensor
 Support edge motion
 Support virtual scroll bar
 Support 2 or 3 button mode
 ESD withstand: 15KV
 Power Consumption: 2.75mA / 5V
 X/Y resolution: 500 points/inch
 Interface: PS/2

6.7 KEYBOARD

Supplier : KC Matrix-290
 Travel : 3.0 ±0.2mm
 Support : 3 window keys
 Key pitch : 19mm
 Dimension : 249mm x 100.85mm x 7.8 mm

6.8 MODEM/FAX MODULE

Modem chip : LUCENT DSP1645 + CSP1034AH + CSP1027
 Meet PC99 Window modem requirement
 Support :
 3.3V PCI bus / V.80 (for H.324) / DSVD(V.70) / half duplex speaker phone
 V.34bis / AT command set / V.42 (LAPM) and MNP error correction
 V.42bis and MNP5 data compression / 56Kflex protocol / V.17, V.29, V.27ter, V.21ch2
 / VI Group III fax / telephony answering machine / DTMF generation and
 detection / V11. Local handset, telephone and microphone record / telephone
 line and headset or VIII. Peaked playback / voice view / caller ID / host base
 DSVD
 Power : active=450mW idle=160mW sleep=10mW

Notebook PC Service Manual

Model : 340S2

Chapter 7 Explosion Diagram

UNIWILL COMPUTER CORP.

No. 24 Pei Yuan Road
Chung Li Industrial Park, Chung Li City
Tao Yuan Hsien, Taiwan
R.O.C.
TEL: 886-3-461-6000
FAX: 886-3-461-6317
URL: [http:// www.uniwill.com.tw/](http://www.uniwill.com.tw/)

7.1 TOP CABINET ASSEMBLY

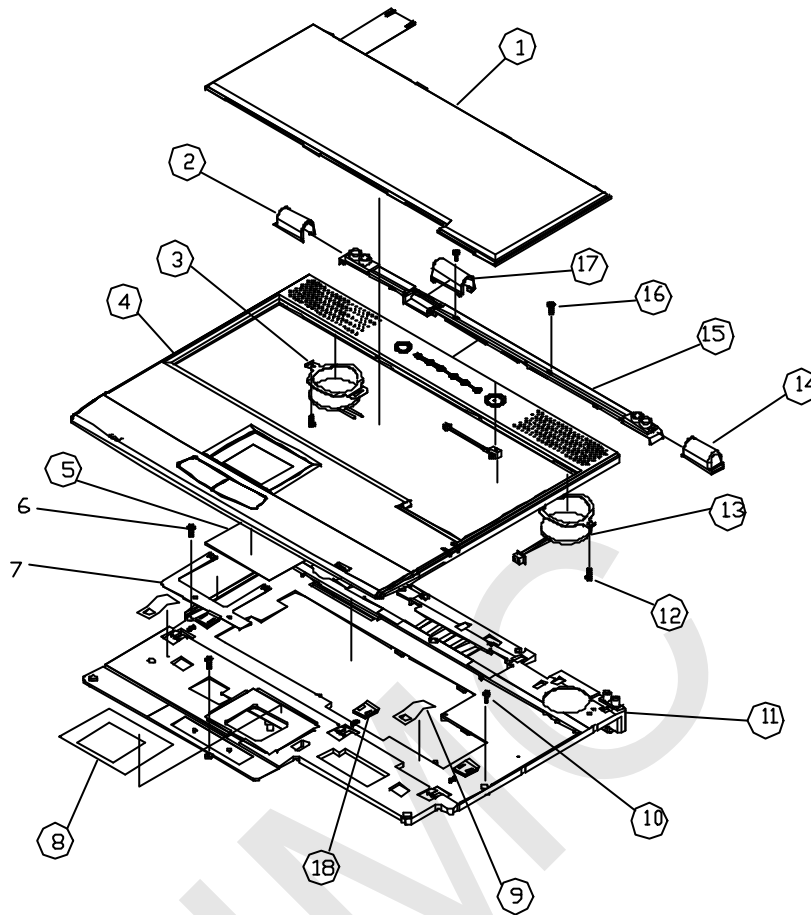

NO.	PART NUMBER	DESCRIPTION
1	71-002901-00	K/B US
2	50-352924-00	COVER HINGE (L) 340
3	40-102902-00	SPRING SPK 340
4	50-312927-00	TOP CAB. ASSY – ID2
5	74-08U204-00	T/P
6	41-720120-06	M2.0*6
7	7915034020	FPC T/P PAD
8	50-212904-00	ADHESIVE TAPE
9	40-102901-00	SPRING FOR K/B 340
10	41-720120-04	M2.0*4
11	50-312903-00	TOP HOUSING (MG) 340
12	41-720120-03	M2.0*3
13	22-300513-00	SPEAKER FG-36N081
14	50-352922-00	COVER HINGE (R) 340
15	50-352921-00	COVER HINGE FRAME
16	41-720120-03	M2.0*3
17	50-352924-00	COVER CABLE FOR 340
18	50-432911-00	LATCH K/B FOR (BLACK)

7.2 PCB (MOTHERBOARD) ASSEMBLY

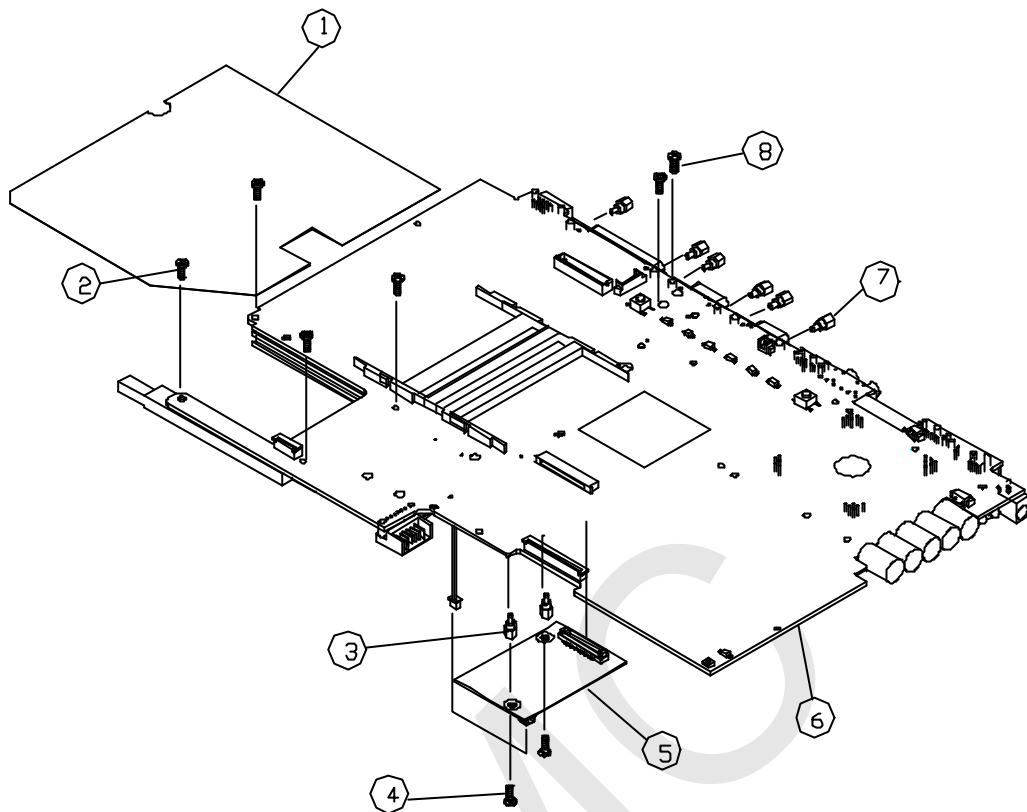

NO.	PART NUMBER	DESCRIPTION
1	7914129030	MYLAR CD-ROM 340
2	41-720120-08	SCREW M2.0*8
3	41-300002-04	HEX M2.0*3(HEX*3)CU
4	41-720120-04	M2.0*4
5	76-0U0137-00	MODEM CARD
6	581510385AP	M/B ASSY
7	41-300002-21	HEX D4.8*10.2L
8	41-720120-06	SCREW M2.0*6

7.3 BASE CABINET ASSEMBLY

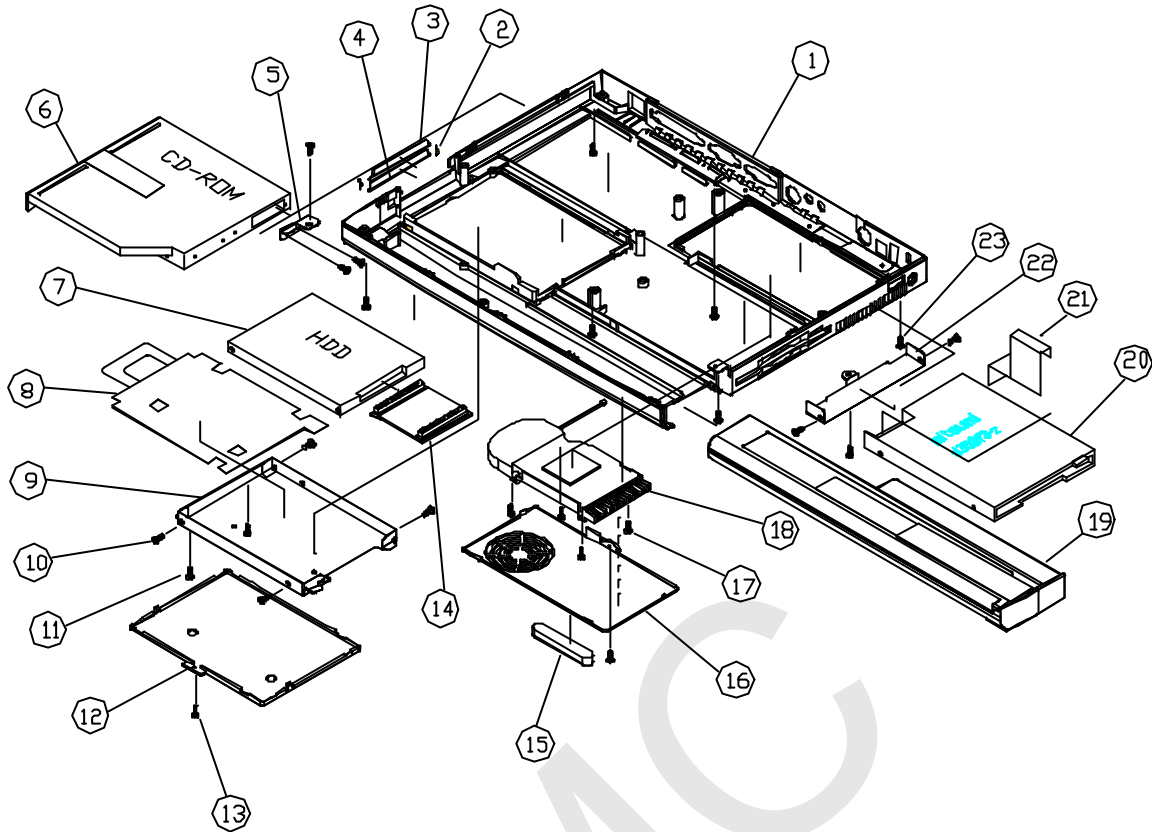

NO.	PART NUMBER	DESCRIPTION
1	50-322903-00	BOTTOM CAB ASSY W/OUT TV OUT
2	40-102904-00	SPRING PCMCIA DOOR
3	50-202907-00	DOOR PCMCIA (U) 340
4	50-202908-00	DOOR PCMCIA (L) 340
5	40-302913-00	BRACKET CDROM 340
6	5810503401P	CD-ROM ASSY 24X QUANTA
7		HDD
8	50-212902-00	MYLAR HDD 340
9	50-502902-00	PLATE HDD 340
10	41-760230-03	SCREW M3.0*3
11	41-720120-04	SCREW M2.0*4
12	50-202906-00	DOOR HDD 340
13	41-720120-04	SCREW M2.0*4
14	29-102907-00	CABLE HDD 340
15	52-002901-00	RUBBER FOOT 340
16	50-202905-00	DOOR CPU 340
17	791C250452	SCREW M2.5*4.5 PAN
18	27-322911-00	THERMAL MODULE FOR 340S2
19	23-523200-21	BATTERY Li-Ion 3200mAH PAN.
20	5810603401P	FDD ASSY MITSUMI
	5810603402P	FDD ASSY TEAC
21	29-163403-00	FFC FDD
22	40-302914-00	BRACKET FDD 340
23	41-720725-08	SCREW M2X0.45X8

7.4 LCD ASSEMBLY

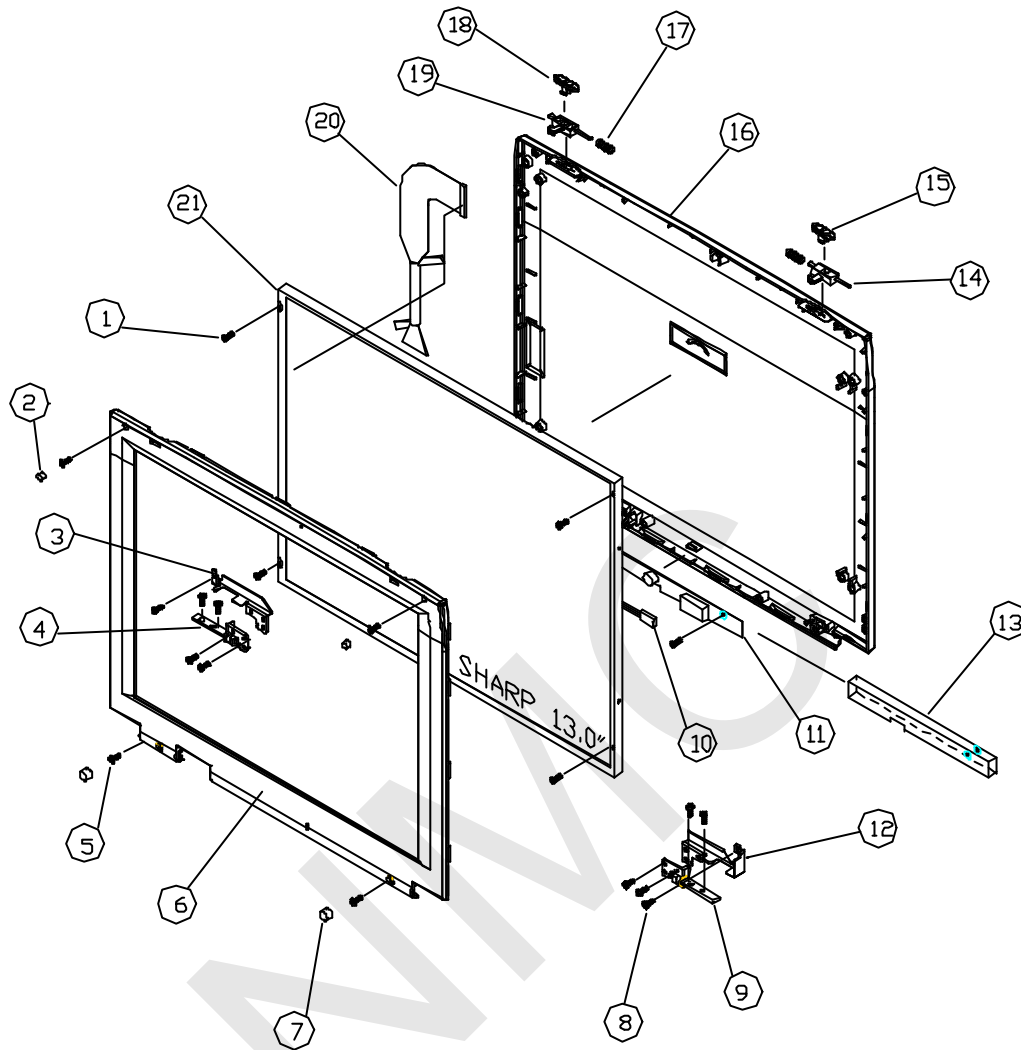

NO.	PART NUMBER	DESCRIPTION
1	41-720525-06	SCREW M2.5*6
2	52-012919-00	RUBBER FOR DISPLAY (T) 340
3	40-302905-00	BRACKET (L) FOR LCD
4	40-152907-00	HINGE (L) A-TYPE 340
5	41-720525-06	SCREW M2.5*6
6	50-332921-00	FRONT CAB 14.1
7	52-012911-00	RUBBER FOR DISPLAY (B)
8	41-720120-04	SCREW M2.0*4
9	40-152909-00	HINGE (R) A-TYPE 340
10	29-102901-00	CABLE FOR LCD INVERTER 14.1
11	76-030533-00	INVERTER FOR 14.1"
12	40-302906-00	BRACKET (R) FOR LCD
NO.	PART NUMBER	DESCRIPTION
13	50-212900-00	MYLAR FOR INVERTER 340
14	50-242910-00	HOOK LCD (R) 340
15	50-412906-00	KNOB LCD (340)

16	50-342961-00	BACK CABINET
17	40-101603-00	SPRING LCD GE-6200
18	50-412906-00	KNOB LCD 340
19	50-242910-00	HOOK LCD (L) 340
20	29-012900-30	CABLE FOR LCD
21	58103A55D1P	LCD 14.1" T CHI

Notebook PC Service Manual

Model : 340S2

Chapter 8 Global Support

UNIWILL COMPUTER CORP.

No. 24 Pei Yuan Road
Chung Li Industrial Park, Chung Li City
Tao Yuan Hsien, Taiwan
R.O.C.
TEL: 886-3-461-6000
FAX: 886-3-461-6317
URL: [http:// www.uniwill.com.tw/](http://www.uniwill.com.tw/)

Global Support

UNIWILL COMPUTER CORP.

Taiwan:

24, Pei-Yuan Rd., Chungli Industrial Park, Tao-Yuan Hsien, TAIWAN, R.O.C.

Tel: 886-3-4616000 Ext. 1542, Fax: 886-3-4616317

UNIWILL COMPUTER (EURO) B.V.

NetherLands:

Tarweweg 5, 6534 AM Nijmegen, The Netherlands

Tel: 31-24-388-3255, Fax: 31-24-356-5343

UNIWILL COMPUTER (US):

46716 Lakeview Blvd., Fremont, CA94538, USA

Tel: 1-510-580-6888, Fax: 1-510-580-5666

UNIWILL		RMA Number Request Form																				
CUSTOMER :			TEL :			DATE (YY/MM/DD) :																
REQUESTOR :			FAX :			PAGE : <u> 1 </u> OF <u> 1 </u>																
ADDRESS :						EMAIL :																
ITEM	SERIAL NUMBER	MODEL / PART NAME	FAILURE SYMPTOM	QTY.	CPU	RAM SIZE	LCD	HDD	BATTERY	FDD / LS120	CDROM / DVD	CDROM CABLE	MODEM CARD	LAN CARD	AC-DC ADAPTOR	POWER CORD	USER MANUAL	UTILITY CD	DRIVER DISKETTE	CARRY BAG	IN-WARRANTY	
1																						
2																						
3																						
4																						
5																						
6																						
7																						
8																						
9																						
10																						
UNIWILL Customer Service Division			TEL : 886-3-4616000			FAX : 886-3-461-6384																
ADDRESS : 24, PEI YUAN RD., CHUNGLI INDUSTRIAL PARK, TAO YUAN, TAIWAN, ROC						EMAIL : cs_chi@uniwill.com.tw																
CUSTOMER Signature :			UNIWILL Approval:			Issued By :		Date :														
Request Date :			RMA Number:			Received By:		Date :														
						Approved By :		Date :														

ST2S-01B

Remark: Any pertinent information you can provide us to expedite our response will be greatly appreciated. When filling up information in the "failure symptoms" space, please note the following: 1. Possibility of duplicating the problem for our study purposes. 2. Frequency of problem occurrence 3. Any results from regenerating the problem on the other types of system (e.g., IBM products, any other models of Uniwill machines, etc.) 4. Circumstances that may cause this problem (e.g. making alternations in the system configuration such as installing a video adapter, etc.)

Notebook PC Service Manual

Model : 340S2

Index

UNIWILL COMPUTER CORP.

No. 24 Pei Yuan Road
Chung Li Industrial Park, Chung Li City
Tao Yuan Hsien, Taiwan
R.O.C.
TEL: 886-3-461-6000
FAX: 886-3-461-6317
URL: [http:// www.uniwill.com.tw/](http://www.uniwill.com.tw/)

Table of Contents

Chapter 1. General System Description

Contents :

1.1 System Features	1-2
1.1.1 General	1-2
Features.....	
1.1.2 Hardware	1-2
Specifications.....	
1.2 System Specification	
1.2.1 System	1-4
Board.....	
1.2.1 System Block	1-5
Diagram.....	
1.2.2 LCD	1-6
Display.....	
1.2.3 Power	1-6
Plans.....	
1.2.4 Power Source	1-6
Status.....	
1.2.5 DC/DC	1-7
Board.....	
1.2.6 AC-DC	1-7
Adapter.....	
1.2.7 Inverter.....	1-7
1.2.8 Battery Pack	1-7
.....	
1.2.9 Memory	1-7
Module.....	
1.2.10 Interrupt Request Channel	1-8
.....	
1.2.11 DMA Channel	1-9
.....	
1.2.12 System LED	1-9
Indicator.....	
1.2.13 Hot	1-9
Key.....	

Chapter 2. Connector and Switch Definition

Contents :

2.1 Connector Definitions.....	2-2
2.1.1 Memory DIMM144	2-2
.....	
2.1.2 Modem/B	2-3
.....	
2.1.3 LCD	2-3
.....	
2.1.4 Inverter	2-4
.....	
2.1.5	2-4
CRT.....	
2.1.6	2-4

USB.....	
2.1.7.....	2-5
RJ45.....	
2.1.8.....	2-5
RJ11.....	
2.1.9 Modem Phone and Modem.....	2-5
.....	
2.1.10 MDC.....	2-5
.....	
2.1.11 MIC Jack.....	2-6
.....	
2.1.12 Speaker.....	2-6
Jack.....	
2.1.13 R/L Speaker.....	2-6
.....	
2.1.14 PCMCIA.....	2-7
.....	
2.1.15.....	2-7
HDD.....	
2.1.16.....	2-8
CDROM.....	
2.1.17.....	2-8
FDD.....	
2.1.18 Parallel.....	2-9
.....	
2.1.19 Serial... ..	2-9
.....	
2.1.20 LID.....	2-9
2.1.21 Internal KB.....	2-10
2.1.22 Test	2-10
2.1.23 Fan2.....	2-10
2.1.24 Fan1	2-11
2.1.25 PS/2	2-11
2.1.26 Power Switch	2-11
2.1.27 AC	2-11
2.1.28 Battery.....	2-12
2.1.29 Touch Pad.....	2-12
2.1.30 But_SW_0.....	2-12
2.2 Mechanical Buttons and Switch Definition.....	2-13
2.3 Major Components and Connectors Location.....	2-15
 Chapter 3. Major Components	
Contents :	
3.1 Major Component List (Mainboard).....	3-2
3.2 Major Component Pin Assignment.....	3-3
 Chapter 4. System Disassembly	
Contents:	
4.1 System Disassembly.....	4-2
4.2 Top Housing Disassembly.....	4-9
4.3 LCD Panel Disassembly.....	4-10

Chapter 5. Trouble Shooting

Contents :

Troubleshooting List	5-2
5.1 No display (system failure)	5-3
5.2 VGA controller failure	5-4
5.3 LCD no display or invalid picture.....	5-5
5.4 External monitor has no display or color abnormal	5-6
5.5 Memory test error	5-7
5.6 Keyboard test error	5-8
5.7 Touch pad test error	5-9
5.8 Diskette drive test error	5-10
5.9 Hard disk drive test error	5-11
5.10 CMOS test error	5-12
5.11 SIO port test error	5-13
5.12 PIO port test error	5-14
5.13 Audio drive failure	5-15
5.14 No power symptom	5-16
5.15 CDROM Drive test error.....	5-17
5.16 Stopping in LCD screen while booting.....	5-18
5.17 PCMCIA Cardbus failure.....	5-19
5.18 IR Port can't transfer data.....	5-20
5.19 Modem failure.....	5-21

Chapter 6. Peripheral Devices

Contents :

6.1 LCD.....	6-2
6.2 FDD.....	6-2
6.3 HDD.....	6-2
6.4 CD-ROM /DVD	6-2
6.5 Battery.....	6-2
6.6 Touch Pad.....	6-3
6.7 Keyboard	6-3
6.8 Modem/Fax Module.....	6-3
6.10 AC Adapter.....	6-4

Chapter 7. Explosion Diagram

Contents :

7.1 Top Cabinet Assembly.....	7-2
7.2 PCB Motherboard Assembly.....	7-3
7.3 Base Cabinet Assembly.....	7-4
7.4 LCD Assembly.....	7-5

Chapter 8. Global Support

8-1

Contents :

Chapter 8. Global Support Problem

8-2

Worksheet.....

NMMC